

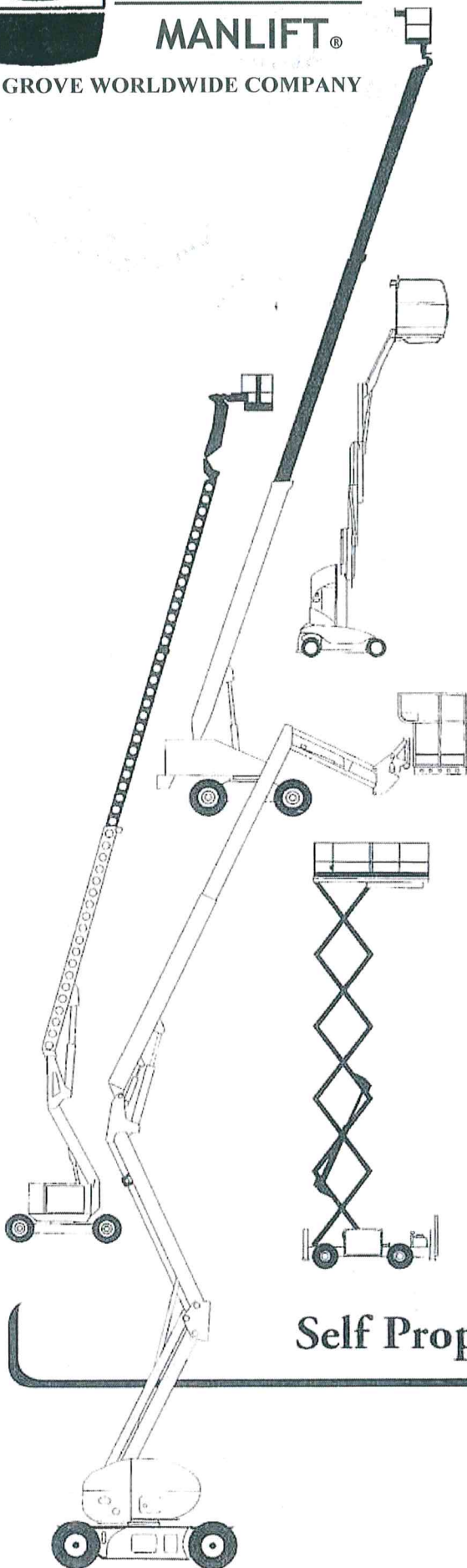

GROVE.
MANLIFT.

A GROVE WORLDWIDE COMPANY



Operator's & Safety Maintenance HANDBOOK

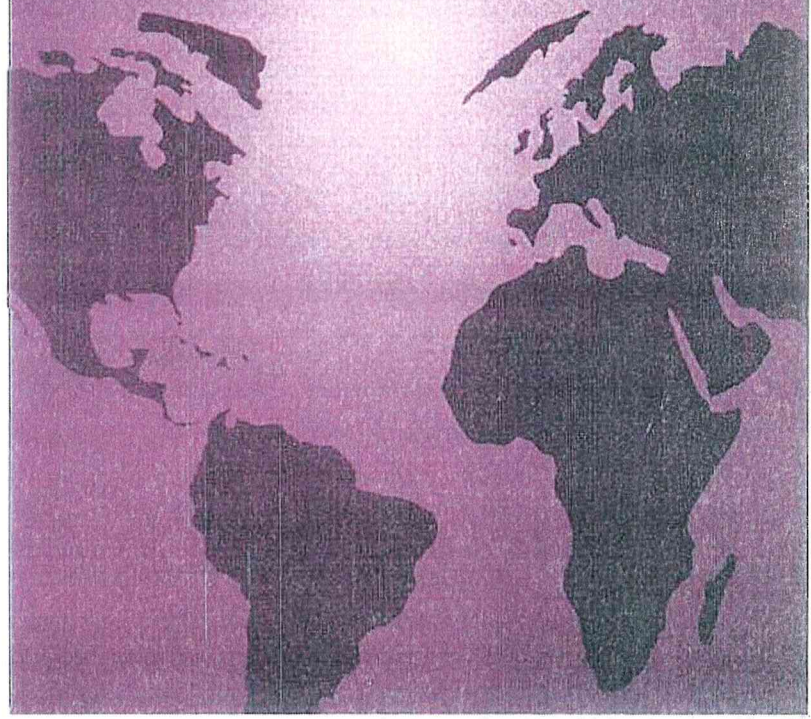

Self Propelled Aerial Work Platforms



GROVE.
MANLIFT

A GROVE WORLDWIDE COMPANY

**OPERATOR'S,
SAFETY,
AND
MAINTENANCE
HANDBOOK**

T60 (MZ66) / T60XT (MZ66XT)

S/N _____



DANGER

DEATH OR SERIOUS INJURY Could Result From Failure to Read, Understand, and Obey the Following Safety Rules. Refer to the Operator's and Safety Handbook for Further Instructions. Prior to Any Operation, Inspect the Entire Work Site and all Ground Conditions Where the Work Platform Will Travel During Operation.

QUALIFIED OPERATOR

DO NOT operate this machine unless you are qualified by training experience in the safe operation of this machine.

Training includes complete knowledge of your employer's work rules, the Operator's and Safety Handbook, and all governmental regulations relative to this machine.

An Untrained Operator Subjects Himself and Others to Death or Serious Injury.

SERVICE & MAINTENANCE

- This machine MUST NOT be used unless it is operating properly.
- This machine MUST BE properly inspected, maintained, and serviced.
- Perform ALL periodic inspections and maintenance specified by the Manufacturer, OSHA, ANSI, and other Government Agencies.
- Allow ONLY authorized service and repairs to be performed on this machine.
- DO NOT modify machine, substitute parts, or change any hydraulic, electrical, or operator aid settings without obtaining written approval from Grove Worldwide.
- DO NOT remove any decal or the Operator's and Safety Handbook from this machine.

11357



DANGER

DEATH OR SERIOUS INJURY Could Result From Failure to Read, Understand, and Obey the Following Safety Rules. Refer to the Operator's and Safety Handbook for Further Instructions. Prior to Any Operation, Inspect the Entire Work Site and All Ground Conditions Where the Work Platform Will Travel During Operation.

CRUSHING HAZARD



- Clear ALL personnel from the counterweight and superstructure area before lowering the boom and/or riser or rotating the superstructure.

11321

⚠ DANGER

DEATH OR SERIOUS INJURY Could Result From Failure to Read, Understand, and Obey the Following Safety Rules. Refer to the Operator's and Safety Handbook for Further Instructions. Prior to Any Operation, Inspect the Entire Work Site and All Ground Conditions Where the Work Platform Will Travel During Operation.

FALLING HAZARD



- DO NOT operate platform unless all platform railing is in place and secured.
- An adequate fall protection device with lanyard attached must be worn by all personnel occupying the platform.
- Maintain a firm footing on platform floor at all times.

TIP-OVER HAZARD



- DO NOT overload platform.
- Ensure that load is secure and evenly distributed.
- Operate platform ONLY on firm level surfaces.
- DO NOT drive platform into drop-offs, holes, curbs, or other obstacles on the ground.
- DO NOT operate platform in excessive wind.

11894

⚠ DANGER

DEATH OR SERIOUS INJURY Could Result From Failure to Read, Understand, and Obey the Following Safety Rules. Refer to the Operator's and Safety Handbook for Further Instructions. Prior to Any Operation, Inspect the Entire Work Site and All Ground Conditions Where the Work Platform Will Travel During Operation.

ELECTRICAL HAZARD



- This machine is NOT insulated.
- DO NOT come into contact with or allow inadequate clearance from electrical power lines or equipment.
- Maintain a MINIMUM clearance of 20 feet from all electrical power lines or equipment.
- KEEP AWAY from machine if it is being operated near electrical power lines or equipment.

11363

IMPORTANT SERVICE INFORMATION

Grove Worldwide and our dealer network want to ensure your satisfaction with our products and customer support services. Your local dealer is the best equipped and most knowledgeable resource available for help with parts, service, and warranty issues. They have the facilities, parts, factory-trained personnel, and on-hand information needed to assist you in a timely manner.

We request that you first contact your local dealer for assistance with problems. If you—and your local dealer—determine that you do need factory assistance, please have your local dealer's service management section coordinate the factory-assistance contact for you.

NOTICE TO OWNER/USER

Should this work platform become involved in an accident, please contact your local Grove Worldwide Manlift® distributor immediately and relate details of the incident so he can notify Grove U.S. L.L.C.

If the distributor is unknown and/or cannot be reached, please contact:

Grove U.S. L.L.C. Customer Support
1086 Wayne Avenue
Chambersburg, PA 17201, USA

Telephone: (717) 263-5100
Fax: (717) 267-0404

FOREWORD

This operator's, safety, and maintenance handbook has been compiled to help you properly operate and maintain your aerial work platform.

Before placing your work platform in service, thoroughly familiarize yourself with the contents of this operator's, safety, and maintenance handbook and the work platform safety video supplied with your machine. Keep the operator's, safety, and maintenance handbook in a readily accessible location for future reference.

Your work platform has been designed for maximum performance with minimum maintenance. With proper care, it will provide years of trouble-free service.

NOTE

Constant improvement and engineering progress require that we reserve the right to make specification and equipment changes without notice.

Detailed operating and routine maintenance procedures are outlined in a work platform-specific repair manual that is available for purchase from Grove U.S. L.L.C. Customer Support.

Information in this operator's, safety, and maintenance handbook does not replace federal, state, or local regulations, safety codes, or insurance requirements.

The definitions of **DANGER**, **CAUTION**, and **NOTE** (as used in this operator's, safety, and maintenance handbook) apply as follows:

DANGER

A DANGER NOTE EMPHASIZES AN OPERATION, PROCEDURE, OR PRACTICE THAT MUST BE FOLLOWED EXACTLY. FAILURE TO FOLLOW OUTLINED PROCEDURES MAY RESULT IN DEATH OR INJURY TO PERSONNEL.

CAUTION

A CAUTION EMPHASIZES THAT IF AN OPERATION, PROCEDURE, OR PRACTICE IS NOT FOLLOWED EXACTLY, EQUIPMENT DAMAGE MAY OCCUR.

NOTE

A note emphasizes an important procedure or condition.

TABLE OF CONTENTS

	Page
Section 1 – SPECIFICATIONS	1-1
Section 2 – SAFETY PRECAUTIONS	2-1
GENERAL	2-1
OPERATOR'S INFORMATION.....	2-1
OPERATOR'S QUALIFICATIONS	2-2
MACHINE STABILITY	2-2
Outriggers/Stabilizers (Optional).....	2-3
FALLING HAZARD.....	2-3
CRUSHING HAZARD.....	2-4
ELECTRICAL POWER SOURCES.....	2-5
MAINTENANCE.....	2-6
Lubrication.....	2-7
Batteries.....	2-7
WORK PRACTICES.....	2-8
Job Preparation.....	2-8
Working.....	2-8
NIGHT OPERATION.....	2-9
Section 3 – WORK PLATFORM CONTROLS	3-1
PLATFORM CONTROLS.....	3-1
Emergency Stop Switch.....	3-1
Cable Backup System Indicator.....	3-1
Start Switch.....	3-1
Horn Switch.....	3-4
Steer Select Switch.....	3-4
Tilt Alarm LED.....	3-4
Lift Controller.....	3-4
Telescope Controller.....	3-4
Drive/Thumb Steer Controller.....	3-4
Swing Controller.....	3-4
Throttle Speed Switch.....	3-4
Function Speed Switch.....	3-5
Platform Rotate Switch.....	3-5
Platform Level Switch.....	3-5
Auxiliary Power Unit Switch.....	3-5
Power Enable LED.....	3-5
Engine Run LED.....	3-5
Footswitch.....	3-5
Work Lights Switch (Optional).....	3-6
Travel Lights Switch (Optional).....	3-6

TABLE OF CONTENTS (CONTINUED)

	Page
Generator Switch (Optional).....	3-6
GROUND CONTROLS	3-6
Ignition Switch.....	3-6
Fuel Select Switch (Dual-Fuel Engine).....	3-6
Voltmeter.....	3-6
Hourmeter.....	3-6
Auxiliary Power Unit Switch.....	3-7
Platform Controls/Ground Controls Selector Switch.....	3-7
Lift Switch.....	3-7
Swing Switch.....	3-7
Telescope Switch.....	3-7
Platform Level Switch.....	3-7
Platform Rotate Switch.....	3-9
OTHER CONTROLS	3-9
Battery Disconnect/Emergency Stop Switch.....	3-9
ALARMS	3-9
Horn/Engine Distress Alarm and Motion Alarm.....	3-9
Tilt Alarm Sensor.....	3-9
 Section 4 – OPERATING PROCEDURES	 4-1
PRE-STARTING CHECKS	4-1
Fuel Supply.....	4-1
Engine Oil.....	4-1
Engine Coolant.....	4-1
Battery.....	4-1
Daily Lubrication.....	4-1
Tires.....	4-1
Hydraulic Reservoir and Filter.....	4-2
Tilt Alarm.....	4-2
Control Operation.....	4-2
Turntable Lock Pin.....	4-2
Air Cleaner.....	4-2
WORK PLATFORM OPERATING TIPS	4-2
Engine Operation.....	4-3
Starting Procedure (Dual-Fuel and Diesel Engines).....	4-3
Cold-Weather Starting.....	4-4
Shutdown Procedure.....	4-4
Dual-Fuel Operation.....	4-4
Converting from Gasoline to LP Gas.....	4-4
Converting from LP Gas to Gasoline.....	4-4

TABLE OF CONTENTS (CONTINUED)

	Page
Emergency Stop.....	4-4
WORK PLATFORM TRAVEL OPERATION.....	4-5
Traveling - General.....	4-5
Emergency Towing.....	4-5
Extended Travel.....	4-6
Moving the Work Platform (Short Distance or Work Mode).....	4-7
Boom Lowered and Boom Retracted Limit Switches.....	4-8
Function Speed Switch.....	4-8
Steering.....	4-8
Traveling.....	4-8
Forward.....	4-8
Stopping.....	4-9
Reverse.....	4-9
GENERAL WORK PLATFORM OPERATION.....	4-9
Ground Controls.....	4-9
Emergency Operation (Auxiliary Power Unit).....	4-9
Pre-Operational Check.....	4-10
WORK PLATFORM FUNCTIONS.....	4-10
Swinging the Boom.....	4-10
Elevating and Lowering the Boom.....	4-10
Elevating the Boom.....	4-10
Lowering the Boom.....	4-11
Telescoping the Boom.....	4-11
Extending the Boom.....	4-11
Retracting the Boom.....	4-11
Platform Rotation.....	4-11
Platform Leveling.....	4-12
Purging the Leveling System.....	4-12
Stowing and Parking.....	4-13
Performing Work on Ships, Barges, and Other Floating Vessels.....	4-13
Section 5 – LUBRICATION.....	5-1
GENERAL.....	5-1
LUBRICATION POINTS.....	5-1
Section 6 – PRESSURE SETTINGS.....	6-1
RELIEF VALVE SETTINGS.....	6-1
Preparation.....	6-2
CHECKING SYSTEM PRESSURE.....	6-2
CHECKING PUMP STAND-BY PRESSURE.....	6-2

TABLE OF CONTENTS (CONTINUED)

	Page
CHECKING RELIEF VALVE ADJUSTMENT.....	6-2
SAC Port Pressure (PR1).....	6-2
Platform Rotate (PR2).....	6-2
Platform Level (PR1).....	6-2
Steer Front and Rear (PR2).....	6-3
Boom Telescope - Out (PR3).....	6-3
Boom Telescope - In (PR4).....	6-3
Boom Lift - Down (PR5).....	6-3
Boom Lift- Up (PR6).....	6-3
Swing (PR7).....	6-4
Section 7 – MAINTENANCE.....	7-1
SYSTEM MALFUNCTIONS.....	7-1
CLEANLINESS.....	7-1
REMOVAL AND INSTALLATION.....	7-1
DISASSEMBLY AND ASSEMBLY.....	7-2
PRESSING PARTS.....	7-2
LOCKS.....	7-2
WIRES AND CABLES.....	7-2
SHIMS.....	7-2
BEARINGS.....	7-2
Antifriction Bearings.....	7-2
Double Row, Tapered Roller.....	7-3
Heating Bearings.....	7-3
Installation.....	7-3
Preload.....	7-3
Sleeve Bearings.....	7-3
GASKETS.....	7-3
BATTERIES.....	7-3
CARE AND INSTALLATION OF TEFLON-COATED BUSHINGS.....	7-3
Bushings.....	7-3
Shafts.....	7-3
Bushings and Shaft.....	7-4
HYDRAULIC SYSTEMS.....	7-4
Cleanliness.....	7-4
Keep the System Clean.....	7-4
Sealing Elements.....	7-4
Hydraulic Lines.....	7-4
Removing Air from the Hydraulic System.....	7-4
FATIGUE OF WELDED STRUCTURES.....	7-5
Welding from/on Work Platforms.....	7-5

TABLE OF CONTENTS (CONTINUED)

	Page
LOCTITE®.....	7-6
FASTENERS AND TORQUE VALUES.....	7-6
LUBRICATION.....	7-11
PROCEDURE FOR PROPER APPLICATION OF PRIMER AND ADHESIVE SEALANT.....	7-11
Primer Application.....	7-11
Adhesive/Sealant Application.....	7-11
Section 8 – PREVENTIVE MAINTENANCE AND INSPECTION.....	8-1
GENERAL.....	8-1
REQUIRED PREVENTIVE MAINTENANCE AND INSPECTION.....	8-1
Daily Preventive Maintenance and Inspection.....	8-1
Weekly Preventive Maintenance and Inspection.....	8-2
Semiannual/Annual Preventive Maintenance and Inspection.....	8-2
Monthly Preventive Maintenance and Inspection.....	8-2
Quarterly Preventive Maintenance and Inspection.....	8-2
Section 9 – TRANSPORTATION VEHICLE PREPARATIONS.....	9-1
TRANSPORTATION VEHICLE PREPARATIONS.....	9-1
PREPARATION OF THE WORK PLATFORM FOR TRANSPORT.....	9-2
PERFORM THE FOLLOWING PROCEDURE AFTER REACHING YOUR DESTINATION.....	9-2
Preparation for Operation after Transport.....	9-2

LIST OF FIGURES

Title	Page
Center of Gravity Diagram.....	1-1
Basic Nomenclature.....	1-2
Platform Controls.....	3-2
Ground Controls.....	3-8
Torque Hub - Fill View.....	5-2
Non-Drive Hub.....	5-2
Lubrication Diagram.....	5-6
Nut Identification.....	7-7
Bolt Head Identification.....	7-7
Adhesive/Sealant Application.....	7-11
Transport Procedure Diagram.....	9-3



LIST OF CHARTS

Title	Page
Work Platform Specifications.....	1-3
Engine Specifications.....	1-6
Engine RPM Specifications.....	1-6
Theoretical Gradeability.....	4-6
Lubrication Symbols.....	5-1
T60(MZ66)/T60XT(MZ66XT) Lubrication Chart.....	5-2
Relief Valve Pressure Settings.....	6-4
Loctite® Adhesives.....	7-6
Torque Values for Unfinished Fasteners with No Special Lubrication - Fine Threads.....	7-8
Torque Values in Newton-Meters (Nm) for Metric Fasteners with No Special Lubrication - Coarse Threads.....	7-9
Torque Values in Foot-Pounds for Metric Fasteners with No Special Lubrication - Coarse Threads.....	7-9
Torque Values for Unfinished Fasteners with No Special Lubrication - Coarse Threads.....	7-10
Theoretical Gradeability.....	9-1

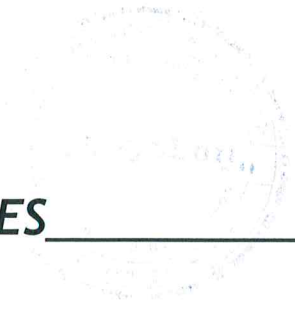

NOTES



SECTION 1

SPECIFICATIONS

This operator's safety, and maintenance handbook provides important information for operators of Grove® Manlift® domestic models T60(MZ66) and T60XT(MZ66XT).

The T60(MZ66) and T60XT(MZ66XT) incorporate an all-welded steel frame. They use hydraulic drive motors and torque hubs to provide two- and four-wheel drive. The axles are integral with the work platform frame. Steering is accomplished as follows:

- 4 X 2 X 4 models - Two steer cylinders (front and rear)
- 4 X 4 X 4 models - Two steer cylinders (front and rear)

An optional oscillating axle is installed on the rear of the work platform. The engine (mounted on the right side of the turntable) provides hydraulic pump drive and electrical generation for work platform functions.

The work platform may be safely driven in the working mode only on firm, level surfaces with a weight equal to—but not exceeding—the manufacturer's rated load in the platform (with the boom in any position).

If the work platform will be traveling over uneven terrain, fully retract and lower the boom so the platform is as close to the ground as possible—while maintaining adequate clearance for the terrain.

Work platform functions are primarily controlled from the platform controls. Some work platform functions can also be controlled from the ground controls (located on the left side of the turntable).

The work platform is equipped with an all-steel, three-section, trapezoidal boom with a V-shaped bottom plate containing a cylinder-extended mid section and a synchronized, leaf chain (with cable backup) extended fly section.

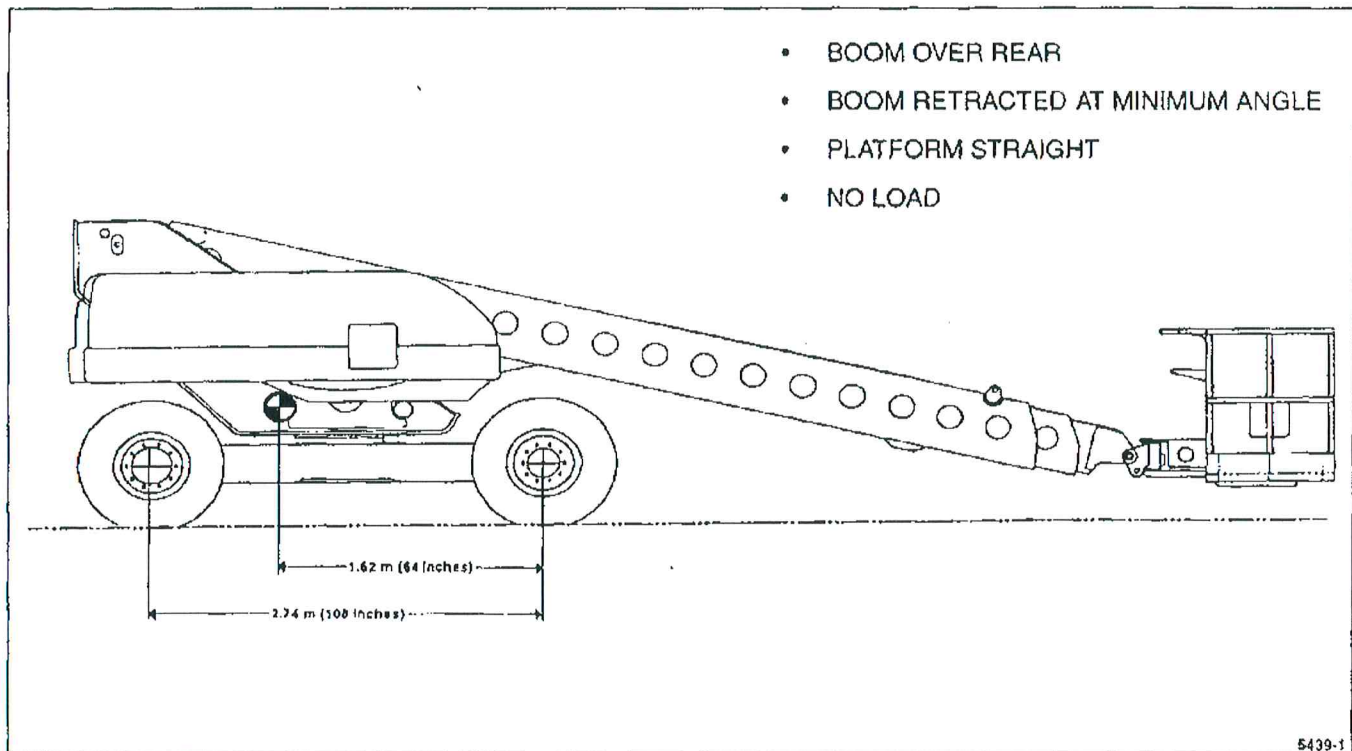

Center of Gravity Diagram

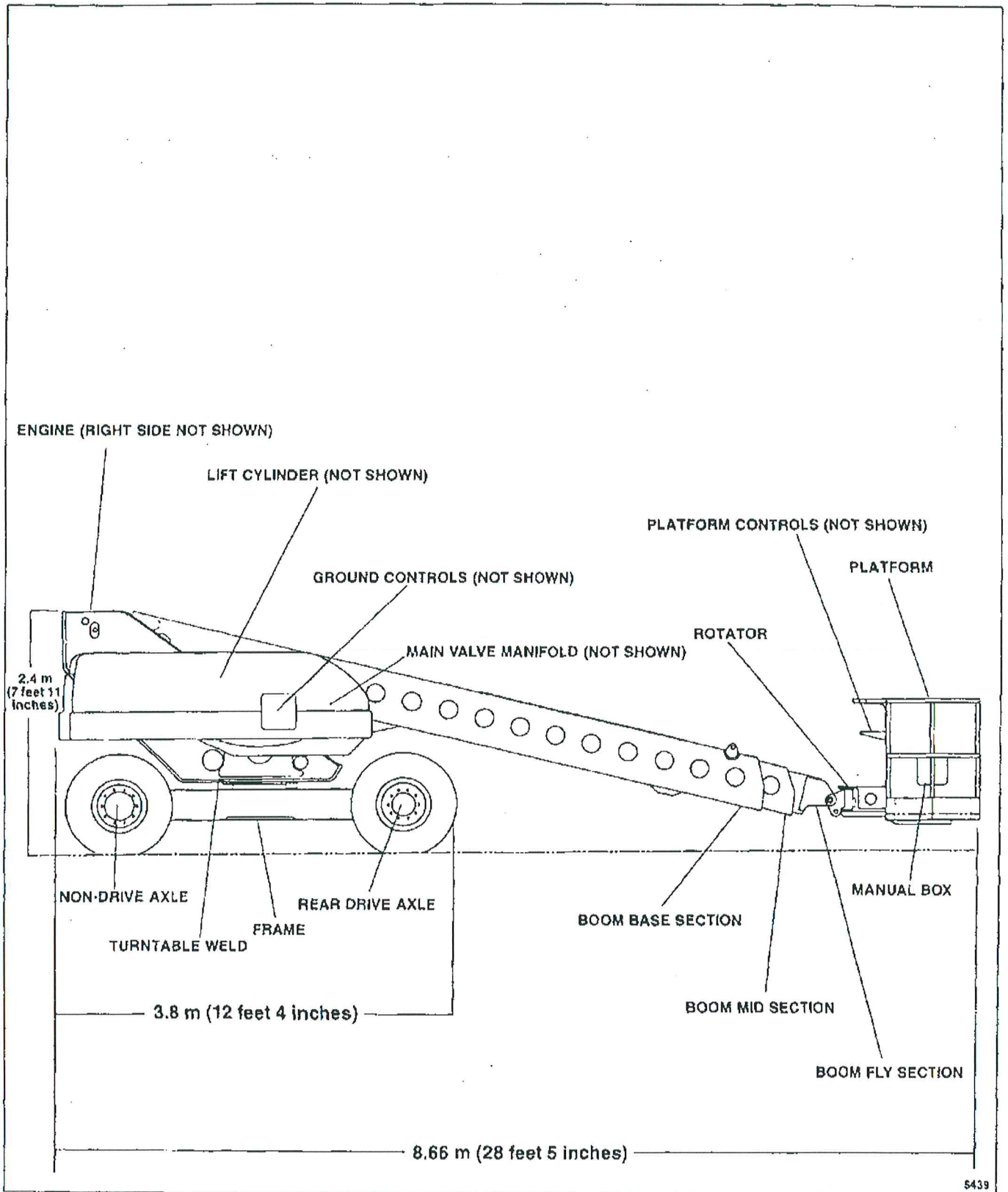

5439

Basic Nomenclature

WORK PLATFORM SPECIFICATIONS

GENERAL

Model T60(MZ66)/T60XT(MZ66XT)

Platform Capacity 227 kg (500 pounds)

Drive

T60(MZ66) Two-wheel drive

T60XT(MZ66XT) Four-wheel drive

Steer

Standard Four-wheel steer

CAPACITIES

Hydraulic Reservoir 136.2 L (36 gallons)

Fuel Tank 102.2 L (27 gallons)

Engine Oil

Deutz F4L-1011 F Diesel (Standard) 13.2 L (14 quarts)

Ford LRG 4.23 Dual Fuel (Optional) 4.71 L (5 quarts)

DRIVE MOTORS

Type Hydraulic Variable Two-Speed Motor

Maximum Displacement (Two-Wheel Drive Models) 2.75 m³/revolution

Minimum Displacement (Two-Wheel Drive Models) 0.945 m³/revolution

BRAKES

Type Spring applied, hydraulically released

WHEELS AND TIRES

Lugs Ten

Tire Size

Domestic Models (Standard) IN395/65D19.5 NHS (15-19.5), 16 ply

Domestic XT Models (Optional) IN395/65D19.5 NHS (15-19.5), 16 ply

Lug Nut Torque

Two-Wheel Drive Models 320 pounds-foot (Drive Hubs)

280 pounds-foot (Non-Drive Hubs)

WORK PLATFORM SPECIFICATIONS

CONFIGURATION	
Safety Rail Height	1.1 m (44 inches)
Kickrail Height	0.1 m (4 inches)
PERFORMANCE	
Gradeability	30%
T60 (MZ66)	
T60XT (MZ66XT)	50%
Turning Radius	
Inside	2.31 m (7 feet 7 inches)
Outside	4.8 m (15 feet 9 inches)
Maximum Drive Speed	6.4 kph (4 mph)
T60 (MZ66)	
T60XT (MZ66XT)	6.4 kph (4 mph)
Engine Horsepower	44.7 kW (60 hp)
Maximum Manual Force	400 N
Maximum Wind Speed	32 kph (20 mph)
GROUND BEARING PRESSURE OF TIRE CONTACT PATCH	
Tire Size	
Standard (Pneumatic)	IND385/65D19.5
Optional (Foam-filled)	IND385/65D19.5
kg/cm ² (psi)	8.50 (121)

ENGINE SPECIFICATIONS

	DEUTZ F4L-1011F (DIESEL ENGINE)	FORD LRG 4.23 (DUAL FUEL)
Type	4 cylinder, 4 cycle diesel	4 cylinder, dual fuel (liquid withdrawal)
Horsepower (SAE Gross Intermittent)	44.8 kw @ 3.000 rpm	47.0 kw @ 2.800 rpm
	60.0 hp @ 3.000 rpm	63.0 hp @ 2.800 rpm
Horsepower @ Governed rpm	38.7 kw @ 2.600 rpm	40.3 kw @ 2.600 rpm
	52.0 hp @ 2.600 rpm	54.0 hp @ 2.600 rpm
Torque(Peak)	161 Nm @ 1.800 rpm	167 Nm @ 2.200 rpm
	142.8 cu. in. @ 1.800 rpm	147.6 cu. in. @ 2.200 rpm
Cooling	Air	Water
Muffler	Non-spark arresting	Spark arresting
Air Cleaner	Dual stage	Single stage
Alternator Rating	14V/60A	12V/95A

ENGINE RPM SPECIFICATIONS

ENGINE	IDLE	GOVERNED RPM FULL LOAD	GOVERNED RPM NO LOAD
Standard Deutz F4L-1011F (Diesel)	1,450- 1,550 rpm	2,250-2,350 rpm	2,360 - 2,460 rpm
Optional Ford LRG 4.23 (Dual Fuel)	1,600 rpm	2,600 rpm	2,600 rpm

SECTION 2

SAFETY PRECAUTIONS

GENERAL

NOTE

Illustrations in this section emphasize certain proper and improper points. READ AND FOLLOW PRINTED INSTRUCTIONS.

It is impossible to compile a list of safety precautions covering all situations. However, there are basic safety precautions that you **MUST** follow during your daily routine. Safety is **YOUR PRIMARY RESPONSIBILITY**. Any piece of equipment is only as safe **AS THE PERSON AT THE CONTROLS**.

This section is designed to help you promote a safe working atmosphere by presenting basic safety precautions you should follow in daily operation. It is not meant to cover every conceivable circumstance that could arise.

If you have questions on operating procedures, work platform usage, or any other applications, contact your local authorized Grove Worldwide distributor.

	DEFINITIONS
Work Platform (Elevating Work Platform)	A self-propelled, vertically adjustable, integral frame platform used to position personnel (and their tools and necessary materials) at overhead work locations.
Platform	The portion of the work platform intended to be occupied by personnel, tools, and necessary materials.

Because you are the only part of the work platform that can think and reason, your responsibility is not lessened by the addition of warning devices or operational aids. Indeed, you must guard against acquiring a false sense of security when using them.

Warning devices and operational aids are there to assist, **NOT** direct the operation. Warning devices can be mechanical, electrical, electronic, or a combination thereof. They are subject to failure or misuse.

You are the only one who can be relied upon to assure the safety of yourself and those around you. Be a **PROFESSIONAL** and follow the **RULES** of safety. **REMEMBER**, failure to follow just one safety precaution can cause an accident to people or equipment. You are responsible for the safety of yourself and those around you.

IMMEDIATELY report all accidents, malfunctions, and equipment damages to your employer and your local authorized Grove Worldwide distributor to advise them of the incident and consult on necessary inspections and repairs.

Do not return the work platform to service until it has been thoroughly inspected for damage and all damaged parts have been repaired or replaced.

OPERATOR'S INFORMATION

NOTE

Information regarding the work platform's rated capacity and operating conditions is given on the capacity plate. The capacity plate is located in the platform adjacent to the platform controls.

You must **READ** and **UNDERSTAND** the Operator's and Safety Handbook and **VIEW** the work platform **SAFETY VIDEO** (provided with your machine) before you operate the work platform. Keep the Operator's and Safety Handbook with the work platform at all times—in a readily available location.

Make sure all personnel occupying the platform (and also ground personnel) are thoroughly familiar with also safe operating practices. Thoroughly familiarize yourself with the location and content of all placards and decals on the work platform.

Decals provide important instructions and warnings. They must be read prior to any operational or maintenance functions.

You must also familiarize yourself with regulations and standards governing work platforms and their operation. Work practice requirements may vary slightly between government regulations, industry standards, and employer policies so a thorough knowledge of all relevant work rules is necessary.

OPERATOR'S QUALIFICATIONS

DANGER

DEATH OR SERIOUS INJURY Could Result From Failure to Read, Understand, and Obey the Following Safety Rules. Refer to the Operator's and Safety Handbook for Further Instructions. Prior to Any Operation, Inspect the Entire Work Site and all Ground Conditions Where the Work Platform Will Travel During Operation.

QUALIFIED OPERATOR

DO NOT operate this machine unless you are qualified by training experience in the safe operation of this machine.

Training includes complete knowledge of your employer's work rules, the Operator's and Safety Handbook, and all governmental regulations relative to this machine

An Untrained Operator Subjects Himself and Others to Death or Serious Injury

SERVICE & MAINTENANCE

- This machine **MUST NOT** be used unless it is operating properly
- This machine **MUST BE** properly inspected, maintained, and serviced.
- Perform **ALL** periodic inspections and maintenance specified by the Manufacturer, OSHA, ANSI, and other Government Agencies
- Allow **ONLY** authorized service and repairs to be performed on this machine
- **DO NOT** modify machine, substitute parts, or change any hydraulic, electrical, or operator aid settings without obtaining written approval from Grove Worldwide.
- **DO NOT** remove any decal or the Operator's and Safety Handbook from this machine

11357

Do not attempt to operate the work platform unless you have been trained and are thoroughly familiar with all operational functions. Controls, features, and operating procedures may vary from work platform to work platform so it is **ESSENTIAL** that you receive specific training (given by competent, authorized personnel) on the particular machine you will be using.

Never jeopardize your well-being or that of others by attempting to operate a work platform on which you have not been trained. Training is **ESSENTIAL** to proper operation. Safe work practices depend on proper operation.

You must be mentally and physically fit to operate the work platform—and not be under the influence of medication, narcotics, or alcohol. **ANY** type of drug could impair your physical, visual, and mental reactions and capabilities.

MACHINE STABILITY

DANGER

DEATH OR SERIOUS INJURY Could Result From Failure to Read, Understand, and Obey the Following Safety Rules. Refer to the Operator's and Safety Handbook for Further Instructions. Prior to Any Operation, Inspect the Entire Work Site and All Ground Conditions Where the Work Platform Will Travel During Operation.

FALLING HAZARD



- **DO NOT** operate platform unless all platform railing is in place and secured.
- An adequate fall protection device with lanyard attached must be worn by all personnel occupying the platform.
- Maintain a firm footing on platform floor at all times.

TIP-OVER HAZARD



- **DO NOT** overload platform.
- Ensure that load is secure and evenly distributed.
- Operate platform **ONLY** on firm level surfaces.
- **DO NOT** drive platform into drop-offs, holes, curbs, or other obstacles on the ground.
- **DO NOT** operate platform in excessive wind.

11894

DANGER

DO NOT PLACE OBJECTS IN THE WORK PLATFORM WHICH COULD SIGNIFICANTLY INCREASE THE WIND AREA AND THEREFORE AFFECT MACHINE STABILITY.

CAUTION

DO NOT USE THE WORK PLATFORM AS A CRANE.

Be aware of all conditions that could adversely affect the stability of the work platform. Death or serious injury could result from the machine tipping over. Certain precautions must be taken to avoid such possibilities.

Prior to any operation, inspect the ENTIRE work site. This includes checking ground conditions for bumps, holes, drop-offs, obstructions, and slopes. Also look for personnel in areas where the work platform will travel during operation.

Make sure traveling surfaces have a slope of less than 5° and will support a load greater than the work platform's weight. Check the tilt alarm for proper functioning.

Before driving the work platform in close quarters, thoroughly familiarize yourself with the machine's driving, steering, and stopping characteristics.



Operate the work platform ONLY on firm level surfaces. Do not position the work platform near holes or drop-offs. Never drive the work platform into holes, curbs, or other obstacles on the ground. Avoid sudden starts and stops which can produce an increased loading effect. Never apply excessive force to work platform controls.

CAUTION

DO NOT EXCEED PLATFORM'S RATED CAPACITY (PRINTED ON CAPACITY PLATE ON MACHINE). MAKE SURE ANY LOAD ON PLATFORM IS SECURE AND EVENLY DISTRIBUTED.

Do not elevate platform if wind speed exceeds 32 km/h (20 mph),

OUTRIGGERS/STABILIZERS (OPTIONAL)

Extend or retract outriggers/stabilizers (on machines that are so equipped) only when platform is fully lowered. When outriggers are used, do not elevate platform unless work platform is LEVEL and all tires are clear of ground. Place outriggers on a firm surface (cribbing should be used where necessary).

Properly stow outriggers/stabilizers before driving the work platform. Never attempt to drive the work platform with the outriggers/stabilizers lowered.

FALLING HAZARD

! DANGER
DEATH OR SERIOUS INJURY Could Result From Failure to Read, Understand, and Obey the Following Safety Rules. Refer to the Operator's and Safety Handbook for Further Instructions. Prior to Any Operation, Inspect the Entire Work Site and All Ground Conditions Where the Work Platform Will Travel During Operation.

FALLING HAZARD



- DO NOT operate platform unless all platform railing is in place and secured.
- An adequate fall protection device with lanyard attached must be worn by all personnel occupying the platform.
- Maintain a firm footing on platform floor at all times.

TIP-OVER HAZARD



- DO NOT overload platform.
- Ensure that load is secure and evenly distributed.
- Operate platform ONLY on firm level surfaces.
- DO NOT drive platform into drop-offs, holes, curbs, or other obstacles on the ground.
- DO NOT operate platform in excessive wind.

11894

Take every precaution to ensure you do not fall from the platform. Death or serious injury could result from falling out of the platform. Do not operate the work platform unless all platform railing is in place and all gates or openings are closed. An adequate fall protection device with lanyard attached must be worn by all personnel occupying the platform. Close all gates and openings.

When occupying the platform, maintain a FIRM FOOTING on the platform floor at all times. NEVER CLIMB ONTO THE PLATFORM RAILINGS—OR ANY OBJECTS LAYING ON THE PLATFORM FLOOR—TO ATTAIN ADDITIONAL WORKING HEIGHT.

Keep the platform clean and remove debris from shoes before entering the platform. Dirt, debris, liquids, and ice on the platform or access steps could cause a slipping accident.

Only enter and exit the platform by the access steps provided and at the ground level. Maintain at least three-point contact at all times (two hands and one foot or two feet and one hand).

CRUSHING HAZARD



Always be aware of your working environment during work platform operation. Always avoid contacting the work platform and its occupants with external objects during operation. Should contact occur, lower the platform and inspect for damage before continuing operation.

You must always be aware of what is below, above, beside, in front of, and behind the work platform during any elevating, lowering, or driving functions. If you are unable to see clearly in the direction of motion, you should post a lookout or signal person before moving the work platform.

Never ELEVATE the platform into overhead obstructions or put yourself in a position of interference between the platform and overhead objects. Take extreme care to avoid such situations.

Never DRIVE any part of the work platform into obstructions or personnel. Always look in the direction of travel.



Never lower the platform into the ground or attempt to raise the frame with any part of the elevating assembly. When lowering the platform, do not descend onto objects or personnel below. Always check tail swing clearance before swinging boom.

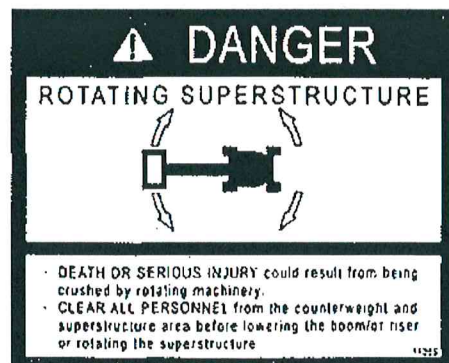

Clear all personnel from the counterweight and superstructure area before lowering the boom or rotating the superstructure.

Do not position any part of the machine close to energized electrical lines and equipment. Maintain a MINIMUM clearance of 6 m (20 feet) from electrical lines and equipment at all times.

ELECTRICAL POWER SOURCES

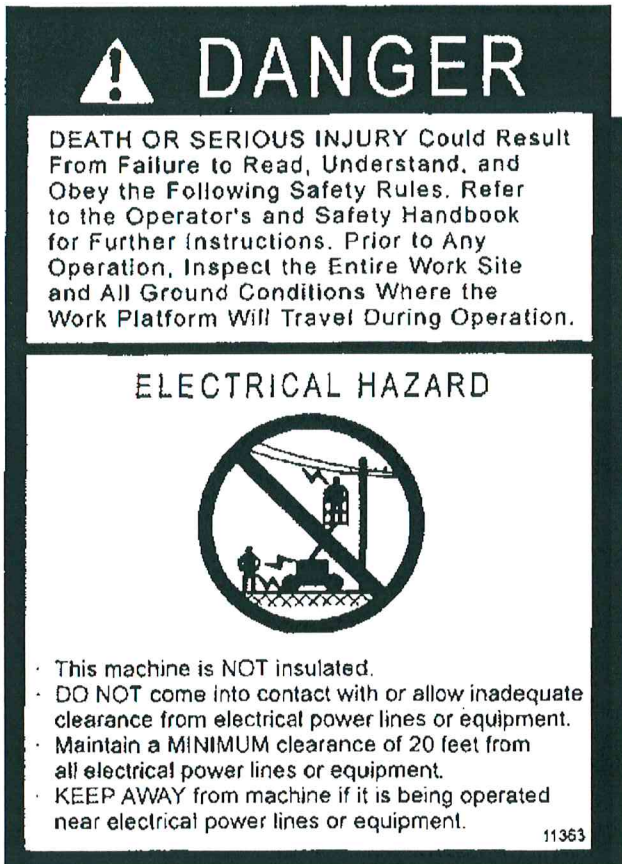

Death or serious injury could result from contact with or inadequate clearance from electrical power lines or equipment. Never operate work platform in proximity to a power source or power line without first notifying the power or utility company. Always obtain positive, absolute assurance that the power has been turned OFF.

During work platform use, assume every line is energized. Take necessary precautions. Alert all personnel of dangers associated with electrical power lines and equipment.

The platform is not insulated. Do not allow unnecessary personnel in the vicinity of the work platform while it is in use. Even if a work platform operator is not affected by an electrical contact, others in the area may become seriously injured or killed.

It is not always necessary to contact a power line or power source to become electrocuted. Electricity (depending on magnitude) can jump or become induced into a work platform. Low voltages can also be dangerous.

Set up (park) the work platform in a position so that no part of the machine can be moved to within 6 m (20 feet) of power lines and equipment. This consideration should include the extremes of the work platform's attainable configurations (e.g. height) when the base is in a stationary position.

Erect a suitable barricade to physically restrain work platform and all attachments from entering into an unsafe distance from power lines and equipment.

Federal law prohibits the use of work platforms closer than 3 m (10 feet) to energized power sources up to 50 KV. Grove Worldwide recommends twice the OSHA minimum distance—6 m (20 feet).

Thoroughly READ and UNDERSTAND all applicable federal, state, and local regulations. Operate the work platform in compliance with these regulations. Using proximity devices or mechanical limit stops does not assure electrical contact will not occur. You

CAUTION

EMC (ELECTROMAGNETIC COMPATIBILITY) OPERATING ENVIRONMENT

THIS PLATFORM IS INTENDED TO BE USED IN INDUSTRIAL- (AS DEFINED IN STANDARDS EN 50081 AND 50082, PARTS 1 AND 2) AND COMMERCIAL-TYPE ENVIRONMENTS. OPERATION OF THE PLATFORM IN CLOSE PROXIMITY TO HIGH-POWERED RADIO TRANSMISSION APPARATUS (EG., AT HOSPITALS, AIRPORTS, MARINE LOCATIONS) MAY AFFECT ONE OR MORE FUNCTIONS OF THE PLATFORM.

must follow the rules and precautions outlined in this handbook at all times regardless of the devices with which the work platform is equipped.

Plan ahead. Always plan a safe route before traveling under power lines. Rider poles should be erected on each side of a crossing to assure sufficient clearance is maintained.

Grounding of a work platform affords little or no protection from electrical hazards. DO NOT depend on grounding.

Overhead lines blow in the wind so allow for this when determining safe operating distances.

If the work platform should come in contact with an energized power source, immediately warn personnel in the vicinity to stay away. Allow no one to use the lower controls at ground level in this situation.

The operator on the platform should attempt to move the work platform away from the power source using the platform controls which are likely to remain functional.

Should the operator become incapacitated or lose functional capability, the power company should be contacted to de-energize the electrical source. NO ONE should attempt to use the lower controls at ground level until the power has been turned off.

Following contact with an energized electrical source, immediately advise your local authorized Grove Worldwide distributor of the incident and consult with him on necessary inspections and repairs.

Do not return the work platform to service until it has been thoroughly inspected for damage and all damaged parts have been repaired or replaced.

MAINTENANCE

Inspect the work platform prior to its use on each work shift. The work platform owner, user, and operator must make sure routine maintenance and lubrication are being dutifully performed. They should NEVER allow a damaged or poorly maintained work platform to be put into service.

⚠ DANGER

DEATH OR SERIOUS INJURY Could Result From Failure to Read, Understand, and Obey the Following Safety Rules. Refer to the Operator's and Safety Handbook for Further Instructions. Prior to Any Operation, Inspect the Entire Work Site and all Ground Conditions Where the Work Platform Will Travel During Operation.

QUALIFIED OPERATOR

DO NOT operate this machine unless you are qualified by training experience in the safe operation of this machine.

Training includes complete knowledge of your employer's work rules, the Operator's and Safety Handbook, and all governmental regulations relative to this machine.

An Untrained Operator Subjects Himself and Others to Death or Serious Injury

SERVICE & MAINTENANCE

- This machine MUST NOT be used unless it is operating properly
- This machine MUST BE properly inspected, maintained, and serviced.
- Perform ALL periodic inspections and maintenance specified by the Manufacturer, OSHA, ANSI, and other Government Agencies
- Allow ONLY authorized service and repairs to be performed on this machine.
- DO NOT modify machine, substitute parts, or change any hydraulic, electrical, or operator aid settings without obtaining written approval from Grove Worldwide
- DO NOT remove any decal or the Operator's and Safety Handbook from this machine

11357

Before work platform use:

- Conduct a visual inspection for cracked welds, leaks, damaged controls or cables, loose or missing bolts and pins, and loose wire connections. Any damaged (broken, leaking, cracked, worn, etc.) item or component must be repaired or replaced.
- Inspect tires for nicks, cuts, embedded stones, and abnormal wear.
- Make sure all bolts and lug nuts are properly torqued.
- Make sure pneumatic tires are inflated to the proper pressure (refer to tire inflation information on platform). When inflating or adding air to tires use a tire cage, clip-on innator, and extension hose. These items will allow you to stand away from the tire when inflating it.

Keep the work platform clean at all times—free of mud, dirt, and grease. Dirty equipment wears out faster and makes good maintenance difficult. Nonflammable cleaning solutions appropriate for the job should be used.

ROUTINE MAINTENANCE and INSPECTION of the work platform must be performed by a qualified person(s) according to recommendations outlined in the Grove Worldwide Manlift® Maintenance and Inspection Manual. Any questions on procedures and specifications should be directed to your local authorized Grove Worldwide distributor.

Only allow qualified personnel to perform work platform service and repairs in accordance with the:

- Manufacturer's recommendations
- Operator's, Safety, and Maintenance Handbook
- Repair Manual designed for this machine

All replacement parts must be Grove Worldwide-approved.

Unless authorized and approved by Grove Worldwide, do not make any modifications, alterations, or changes to a work platform that in any way affect its original design. Such action invalidates all warranties and makes the owner/user liable for any resultant accidents.

Before performing maintenance, service, or repairs on the work platform:

- Properly tag controls. Never operate the work platform if it is TAGGED-OUT. Do not attempt to operate the work platform until it is restored to proper operating condition and all tags have been removed.
- Fully retract and lower the boom. If the boom is not fully retracted, lower it until it is resting on suitable blocking material or support/suspension from above.
- Lower the platform until it is resting on suitable blocking.
- Disconnect the batteries and remove the ignition key.

- Recognize and avoid pinch points while performing maintenance.

After performing maintenance, service, or repairs on the work platform:

- Replace all components, fasteners, guards, and covers that have been removed.
- Reconnect batteries and remove tags.
- Remove blocking and/or supports.
- Perform a function check of operating controls to ensure proper operation. Perform a load test when a structural or lifting member has been involved in a repair.

LUBRICATION

Lubricate the work platform according to factory recommendations for lubrication points, time intervals, and types.

Exercise care when servicing the work platform's hydraulic system. Pressurized hydraulic oil can cause serious injury.

Take these precautions when servicing the hydraulic system:

- Follow the manufacturer's recommendations when adding hydraulic oil to the system.
- Make sure all lines, components, and fittings are tight before resuming operation.
- Use a piece of wood or cardboard when checking for suspected leaks.
- Never exceed the manufacturer's recommended relief valve settings.

BATTERIES

Battery electrolyte must not be allowed to contact the skin or eyes. If this does occur, flush the contacted area with water and consult a doctor immediately.

Follow proper procedures and precautions when checking and maintaining batteries:

- Do not short across the battery posts to check charge. Short circuits, sparks, or flames could cause battery explosion.
- Check electrolyte levels with a flashlight.
- Check battery test indicator on maintenance-free batteries.
- Wear safety glasses.
- Do not break a live circuit at the battery terminal. Disconnect the grounded battery clamp first when removing a battery and connect it last when installing a battery.
- Charge batteries in an open, well-ventilated area that is free of flames, smoking, sparks, and fire. Remove battery caps when charging to allow gases to escape.
- Limit operation of new vehicles (or older vehicles with new batteries) to well below their advertised range for at least the first five cycles and then gradually increase the range.
- Refer to battery disconnect decal on machine for proper connect/disconnect procedures.

WORK PRACTICES

JOB PREPARATION

Inspect the work platform prior to your work shift. Check for cracked welds, other damaged components, and proper tire inflation (consult maintenance and inspection manual and sendee manuals for more information).

Make sure the work platform is fully and properly equipped, including platform railings, access steps, covers, gates, guards, and controls.

Wear proper clothing and person? 1 protective equipment as required by local or job regulations.

Before entering the platform, THOROUGHLY familiarize yourself with the planned route of travel and the area of operation. Make sure you know all surface conditions and the location of overhead obstructions and power lines.

Know the location of the nearest fire extinguisher— and how to use it.

Fuel the work platform ONLY with the engine turned off and no smoking in the vicinity. Do not store flammable materials on the work platform.

Always keep the platform clean—free of dirt, debris, and grease. Anyone entering the platform must first clean his shoes.

WORKING

Do not use the platform to handle bulk materials. The work platform by definition is intended for use to position personnel, their tools, and NECESSARY materials at overhead work locations.

Keep all equipment, tools, and materials used on the platform well organized and evenly distributed. Do not exceed the rated platform capacity. Do not allow ropes, electrical cords, and hoses to tangle during operation. Never use guardrails to handle material.

Operate the work platform slowly and cautiously, looking carefully in the direction of movement. “Stunt driving” and “horseplay” are prohibited. Never allow anyone to hitch a ride or get on or off a moving work platform.

Never operate the work platform outdoors in bad weather.

When traveling between work locations on the job site, engage the turntable lock pin, fully retract the boom, and lower the boom/riser/jib so the platform is as close to the ground as possible while maintaining adequate clearance for the terrain.

Do not allow personnel on the ground to operate, service, or tamper with the work platform when the platform is occupied—except in emergency situations when platform personnel are unable to fully lower and exit the platform.

If welding is being performed by an occupant of the platform, electrodes and holders must be protected from contact with metal components of the platform. Electronic components can be damaged during welding. To avoid damage, disconnect all electronic components prior to performing welding on the machine.

When shutting down the work platform:

- Fully retract boom and lower platform to ground level.
- Swing superstructure and engage turntable lock pin.
- Place controls in neutral position.
- Chock wheels.
- Remove ignition key.

In cold weather, never let skin directly contact metal surfaces. Do not park the work platform where the wheels can freeze to the ground.

Keep the platform free of ice and snow. Remember to use required special cold-weather starting procedures and to allow ample time for hydraulic oil to warm up.

NIGHT OPERATION

Do not operate this machine in low visibility conditions since injuries may occur due to an inability to detect dangerous conditions.

NOTES

SECTION 3

WORK PLATFORM CONTROLS

The work platform can be controlled from two locations:

- The platform controls (mounted on the front railing of the platform)
- The ground controls (located on the left side of the turntable at ground level)

Work platform functions controlled by proportional controllers on the platform controls are controlled by toggle switches (not proportional) on the ground controls. Drive and steer functions are not available on the ground controls.

Controller operation for work platform functions is proportional through a preset range as determined by the FUNCTION SPEED switch. A gradual, smooth deceleration of a function to zero movement occurs when proportional controllers are returned to the neutral position.

Zero movement requires three seconds or less (depending on adjustments made to controllers). When performing functions, work platform operators should leave enough clearance for the additional movement encountered when using the controllers.

The ground controls allow personnel to operate the work platform from ground level without entering the platform when such an operation becomes necessary.

It is mandatory that before operating the work platform, the operator be thoroughly familiar with the operation of all controls.

PLATFORM CONTROLS

NOTE

The following paragraphs describe controls and indicators located on the platform controls. The numbers in () represent index numbers from the figure titled *Platform Controls*.

EMERGENCY STOP SWITCH

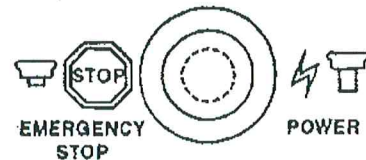

The EMERGENCY STOP switch (1) is located on the bottom left side of the platform controls. Push in on the switch to:

- Remove all electrical power from controls
- Stop engine and all work platform functions

Pull out on the switch before resuming starting operation.

CABLE BACKUP SYSTEM INDICATOR

The cable backup system indicator (2) is located on the bottom left side of the platform controls. This green-light indicator illuminates when the cable backup system is NOT activated. When the cable backup system is activated, the indicator light is OFF.

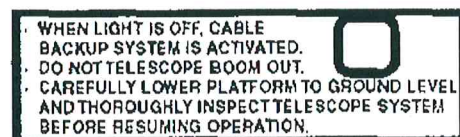

DO NOT telescope the boom out when the system is activated. Carefully lower the platform to ground level. Thoroughly inspect the telescope system before resuming operations.

START SWITCH

The push-button START switch (3) is located on the left side of the platform controls. Push the switch to start the engine. The ground controls IGNITION switch must be in the ON position and the EMERGENCY STOP switch must be pulled up to supply electrical power to the platform controls.

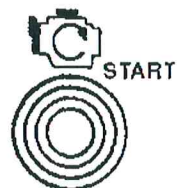

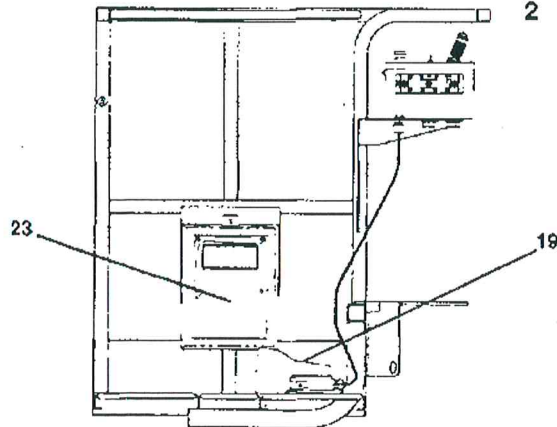
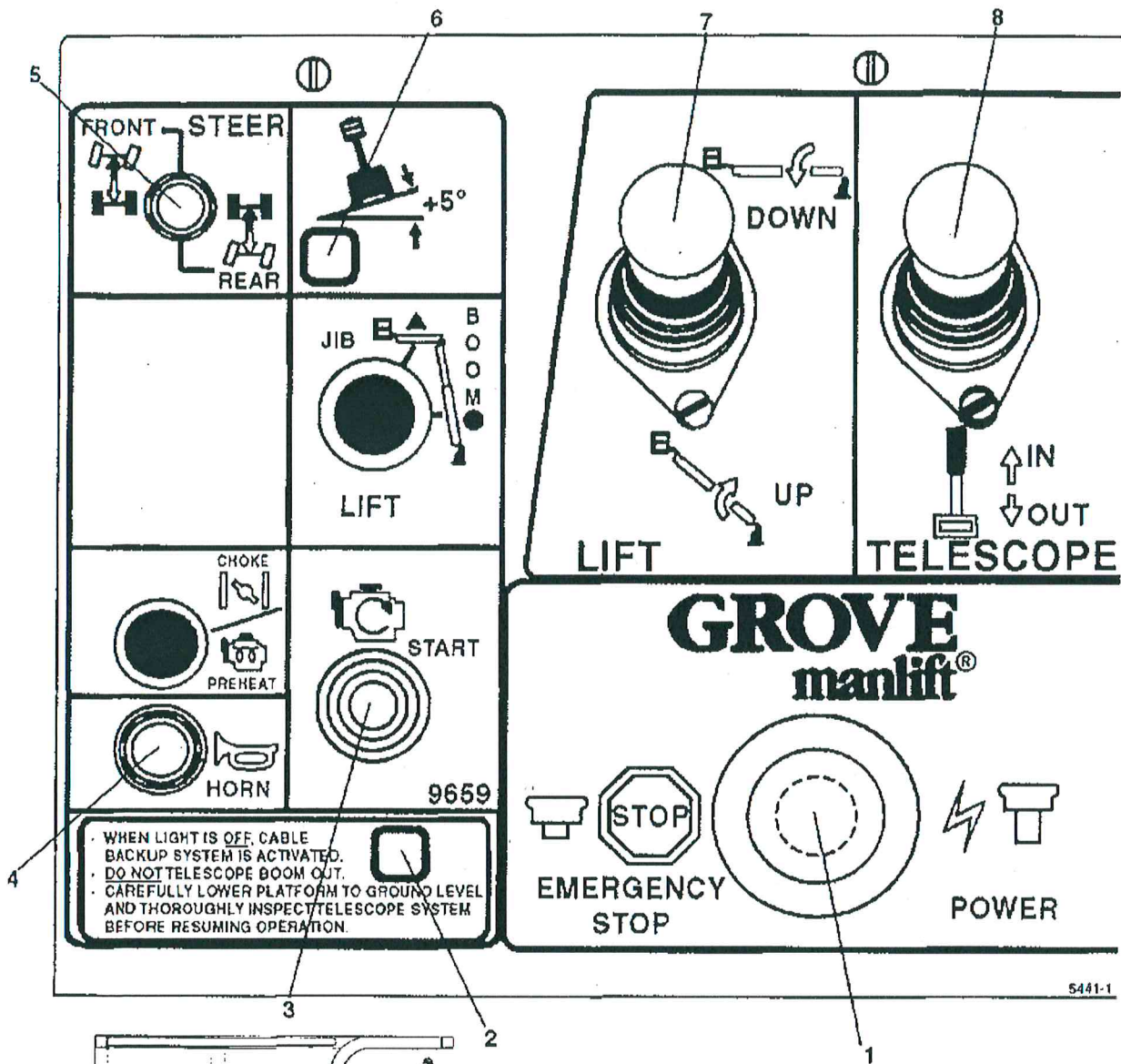

1. Emergency Stop Switch
2. Cable Backup System Indicator
3. Start Switch
4. Horn Switch
5. Steer Select Switch
6. Tilt Alarm LED
7. Lift Controller
8. Telescope Controller
9. Thumb Steer Switch
10. Drive/Thumb Steer Controller
11. Swing Controller
12. Throttle Speed Switch

RIGHT SIDE PLATFORM CONTROLS

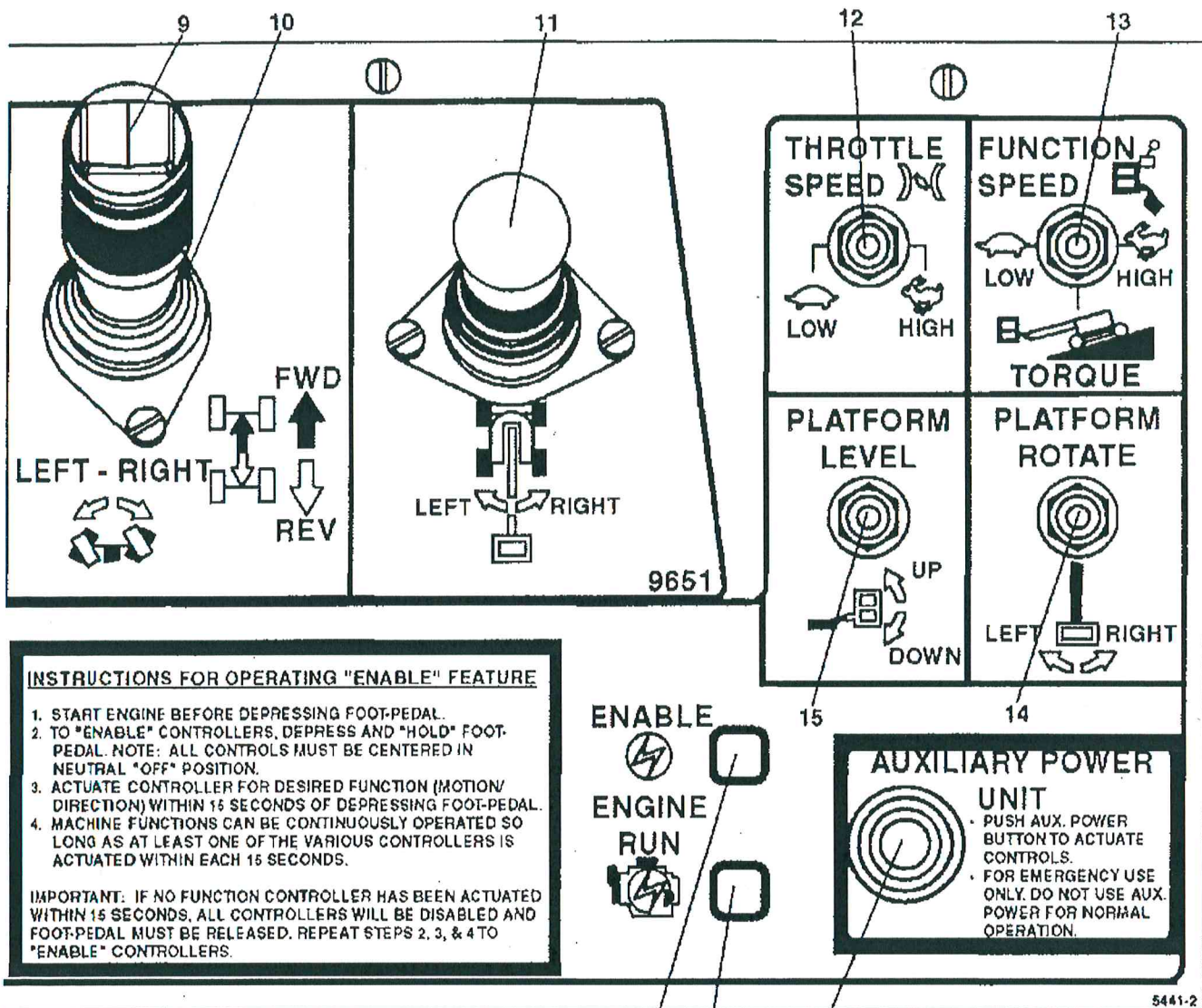

- 13. Function Speed Switch
- 14. Platform Rotate Switch
- 15. Platform Level Switch
- 16. Auxiliary Power Unit Switch
- 17. Power Enable LED
- 18. Engine Run LED
- 19. Footswitch
- 20. Work Lights Switch (Optional)
- 21. Travel Lights Switch (Optional)
- 22. Generator Switch (Optional)
- 23. Manual Box

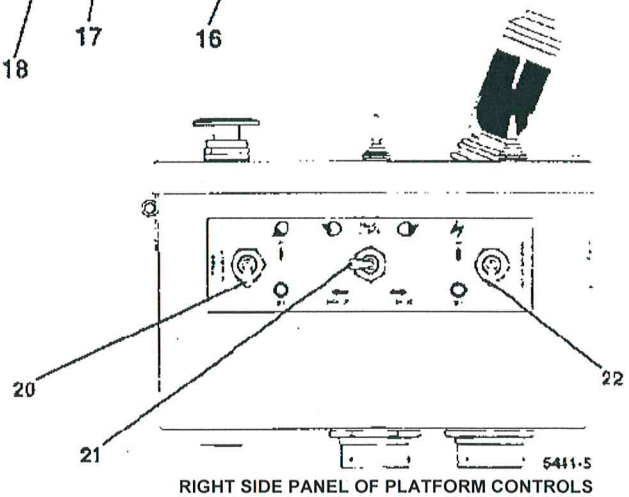

Platform Controls (Sheet 2 of 2)

NOTE

The footswitch must not be depressed to start the machine.

HORN SWITCH

The push-button HORN switch (4) is located on the left side of the platform form controls. Push the switch to sound the horn located on the left side of the turntable in the manifold compartment.



STEER SELECT SWITCH



The STEER SELECT switch (5) is located on the top left side of the platform controls. Position the switch to FRONT or REAR to select the wheels to be used for steering.

TILT ALARM LED

The TILT ALARM LED (6) is located on the left side of the platform controls. This red-light indicator illuminates when the work platform is 5° out of level.



LIFT CONTROLLER

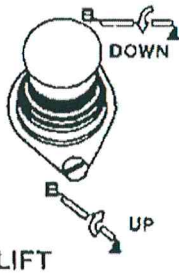

The LIFT controller (7) is located on the left side of the platform controls. Position the controller to either the UP or DOWN position to raise or lower the boom at a proportional speed as selected by the FUNCTION SPEED toggle switch.

- LIFT UP - Pull LIFT controller toward operator
- LIFT DOWN - Push LIFT controller away from operator

TELESCOPE CONTROLLER

The TELESCOPE controller (8) is located on the left side of the platform controls. Position the controller to either the IN or OUT position to extend or retract the boom at a proportional speed throughout each preset range as selected by the FUNCTION SPEED toggle switch.

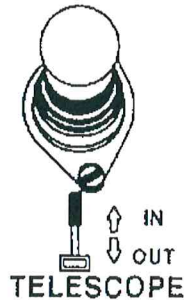

- TELESCOPE OUT - Pull TELESCOPE controller toward operator
- TELESCOPE IN - Push TELESCOPE controller away from operator

DRIVE/THUMB STEER CONTROLLER

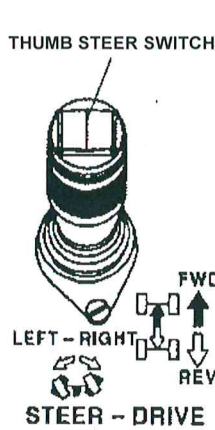

The DRIVE/THUMB STEER controller (10) is located on the right side of the platform controls. The THUMB STEER switch (9) is located on top of the controller.

- Position the controller forward (away from the operator) to FWD or rearward (toward the operator) to REV to hydraulically drive the wheels in the desired direction at the speed you have selected with the FUNCTION SPEED switch.

- Push the left side of the THUMB STEER switch to steer to the left. Push the right side of the THUMB STEER switch to steer to the right.

SWING CONTROLLER

The SWING controller (11) is located on the right side of the platform controls.

Position the controller in the direction of the arrows to either the LEFT or RIGHT to swing the superstructure at a proportional speed throughout each preset range as selected by the FUNCTION SPEED toggle switch.

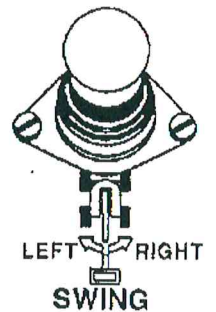

THROTTLE SPEED SWITCH



The THROTTLE SPEED switch (12) is located on the right side of the platform controls.

- Position the switch to the left to LOW, The engine will run at low rpm when a function is selected.
- Position the switch to the right to HIGH. The engine will run at high rpm when a function is selected.

FUNCTION SPEED SWITCH

The FUNCTION SPEED switch (13)—located on the upper right side of the platform controls—controls the speed of the drive motors and function speed range.



- Position the switch to the left to LOW. The drive motors operate in low speed and function speed is in low range.
- Position the switch to the right to HIGH. The drive motors operate in high speed and function speed is in high range.
- Position the switch to the center to TORQUE. The drive motors operate in low speed and drive function speed is in high range.

PLATFORM ROTATE SWITCH

The PLATFORM ROTATE switch (14) is located on the right side of the platform controls. Position the switch to LEFT or RIGHT to rotate the platform in the desired direction.



PLATFORM LEVEL SWITCH

The PLATFORM LEVEL switch (15) is located on the right side of the platform controls. Position the switch in the direction of the arrows to UP or DOWN to manually level the platform.



AUXILIARY POWER UNIT SWITCH

DANGER

THE AUXILIARY POWER UNIT SHOULD BE USED IN EMERGENCY SITUATIONS ONLY. THE OFFICIAL FUNCTION OF THE AUXILIARY POWER UNIT IS TO PROVIDE AN AUXILIARY MEANS OF LOWERING, RETRACTING, AND LEVELING THE WORK PLATFORM IN THE EVENT OF PRIMARY POWER LOSS. ALTHOUGH OTHER FUNCTIONS CAN BE SELECTED, THE APU SWITCH SHOULD ONLY BE USED FOR THE FUNCTIONS LISTED ABOVE.

NOTE

AUXILIARY POWER UNIT (APU) function is Interlocked with all motion commands through the full throttle circuit. This means activating the APU switch (16) alone does not start the APU motor. Activating the APU switch and a motion command is required.

The AUXILIARY POWER UNIT push-button switch (16) is located on the bottom right side of the platform controls. Push and hold the switch—and activate a motion command—to start the motor-driven pump to allow emergency operation of the desired functions.



Due to the decreased amount of hydraulic flow, the functions will operate slowly. Operating time will depend on the condition of the battery.

POWER ENABLE LED

The power ENABLE LED (17) is located on the bottom right side of the platform controls. This green-light indicator illuminates to show that the ENABLE feature has been activated. Refer to the footswitch description in this section for more information on the ENABLE feature.



ENGINE RUN LED



The ENGINE RUN LED (18) is located on the bottom right side of the platform controls. This yellow-light indicator illuminates when the engine is running.

FOOTSWITCH

The FOOTSWITCH (19) is located on the platform floor below the platform controls. With the engine running, depress and hold the footswitch to enable the controllers and switches to perform the desired function.

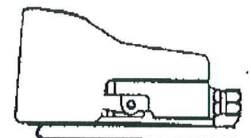

You must actuate a controller or a switch within 15 seconds after you depress the footswitch. If you do not activate a function within 15 seconds after you depress the footswitch, all controllers and switches will be disabled and you must release the footswitch. You must depress the footswitch again to enable the controllers and switches and you must activate a controller or a switch—within 15 seconds after you depress the footswitch—to perform a function. You can continuously operate functions as long as you actuate at least one of the controls within each 15-second time period.

WORK LIGHTS SWITCH (OPTIONAL)



The WORK LIGHTS switch (20) is located on the right side panel of the platform controls. Position the switch to ON to illuminate the work lights located on each side of the platform entrance.

TRAVEL LIGHTS SWITCH (OPTIONAL)

The TRAVEL LIGHTS switch (21) is located on the right side panel of the platform controls next to the WORK LIGHTS switch. Position the switch to BACK-UP to illuminate the back-up lights on the rear of the turntable. Position the switch to DRIVE to illuminate the drive lights on top of the turntable fiberglass cover.

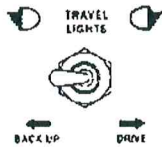

GENERATOR SWITCH (OPTIONAL)

NOTE

Engine must be running.



The GENERATOR switch (22) is a two-position switch located on the right side panel of the platform controls—next to the TRAVEL LIGHTS switch. Position the switch to ON to activate the hydraulic motor that runs the generator. The generator is located on the left rear side of the turntable weld.

GROUND CONTROLS

NOTE

The following paragraphs describe controls and indicators located on the

ground controls. The numbers in () represent index numbers from the figure titled *Ground Controls*.

IGNITION SWITCH



The IGNITION lever selector switch (1) is located on the lower right side of the ground controls. The switch has three positions:

- OFF - Left position
- ON - Vertical position
- START - Right position

The switch is spring returned from the START position to the ON position. The switch must be in the ON position to supply electrical power to the platform controls.

FUEL SELECT SWITCH (DUAL-FUEL ENGINE)

The three-position FUEL SELECT lever selector switch (2) is located on the bottom middle section of the ground controls above the hourmeter.



Position the switch to the left to the fuel pump symbol to allow the dual-fuel engine to run on gasoline as fuel. Position the switch to the right to the LP tank symbol to allow the engine to run on LP gas as fuel.

VOLTMETER



The voltmeter (3) is located on the bottom right side of the ground controls. It indicates the amount of charge or discharge of the battery.

HOURMETER

The hourmeter (4) is located on the bottom left side of the ground controls. It is controlled by the lamp line output from the engine alternator and indicates hours of engine operation.



Use the hourmeter as a guide for determining your engine maintenance, inspection, and overhaul schedules.

AUXILIARY POWER UNIT SWITCH

DANGER

THE AUXILIARY POWER UNIT SHOULD BE USED IN EMERGENCY SITUATIONS ONLY. THE OFFICIAL FUNCTION OF THE AUXILIARY POWER UNIT IS TO PROVIDE AN AUXILIARY MEANS OF LOWERING, RETRACTING, AND ROTATING THE WORK PLATFORM IN THE EVENT OF PRIMARY POWER LOSS. ALTHOUGH OTHER FUNCTIONS CAN BE SELECTED, THE AUXILIARY POWER UNIT SHOULD BE USED ONLY FOR THE FUNCTIONS LISTED ABOVE.

NOTE

AUXILIARY POWER UNIT (APU) function selection is interlocked with all motion commands through the full throttle circuit. This means activating the APU switch alone does not start the APU motor. Activating the APU switch and a motion command is required.

The AUXILIARY POWER UNIT push-button switch (5) is located on the bottom left side of the ground controls. Push and hold the switch—and activate another function—to start the electric motor-driven pump to allow emergency operation of the desired function.

AUXILIARY POWER UNIT



PUSH AUX POWER BUTTON TO ACTIVATE CONTROLS FOR EMERGENCY USE ONLY. DO NOT USE AUX POWER FOR NORMAL OPERATION.

PLATFORM CONTROLS/GROUND CONTROLS SELECTOR SWITCH



The two-position PLATFORM CONTROLS/GROUND CONTROLS rotary selector switch (6) is located on the lower left side of the ground controls. The switch is spring returned up to the PLATFORM CONTROLS position. In this position, the switch controls all electrical power to the platform controls and removes all power from ground control functions.

To operate ground control functions, hold the switch down to the GROUND CONTROLS position.

LIFT SWITCH

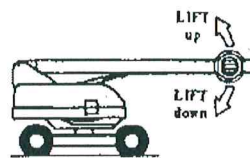

The LIFT switch (7) is located on the left side of the ground controls. Position the switch to either UP or DOWN to raise or lower the boom.

- LEFT UP - Position switch up
- LIFT DOWN - Position switch down

SWING SWITCH

The SWING switch (8) is located on the left side of the ground controls. Position the switch in the direction of the arrows to the LEFT or the RIGHT to swing the turntable in the desired direction.

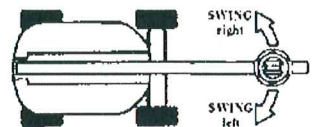

- SWING RIGHT - Position switch up
- SWING LEFT - Position switch down

TELESCOPE SWITCH



The TELESCOPE switch (9) is located in the center of the ground controls. Position the switch in the direction of the arrows to IN or OUT to extend or retract the boom.

- TELESCOPE IN - Position switch to left
- TELESCOPE OUT - Position switch to right

PLATFORM LEVEL SWITCH

The platform LEVEL switch (10) is located on the right side of the ground controls.

Position the switch in the direction of the arrows to UP or DOWN to manually level the platform.

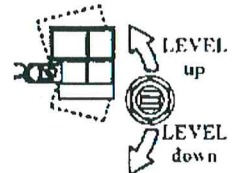

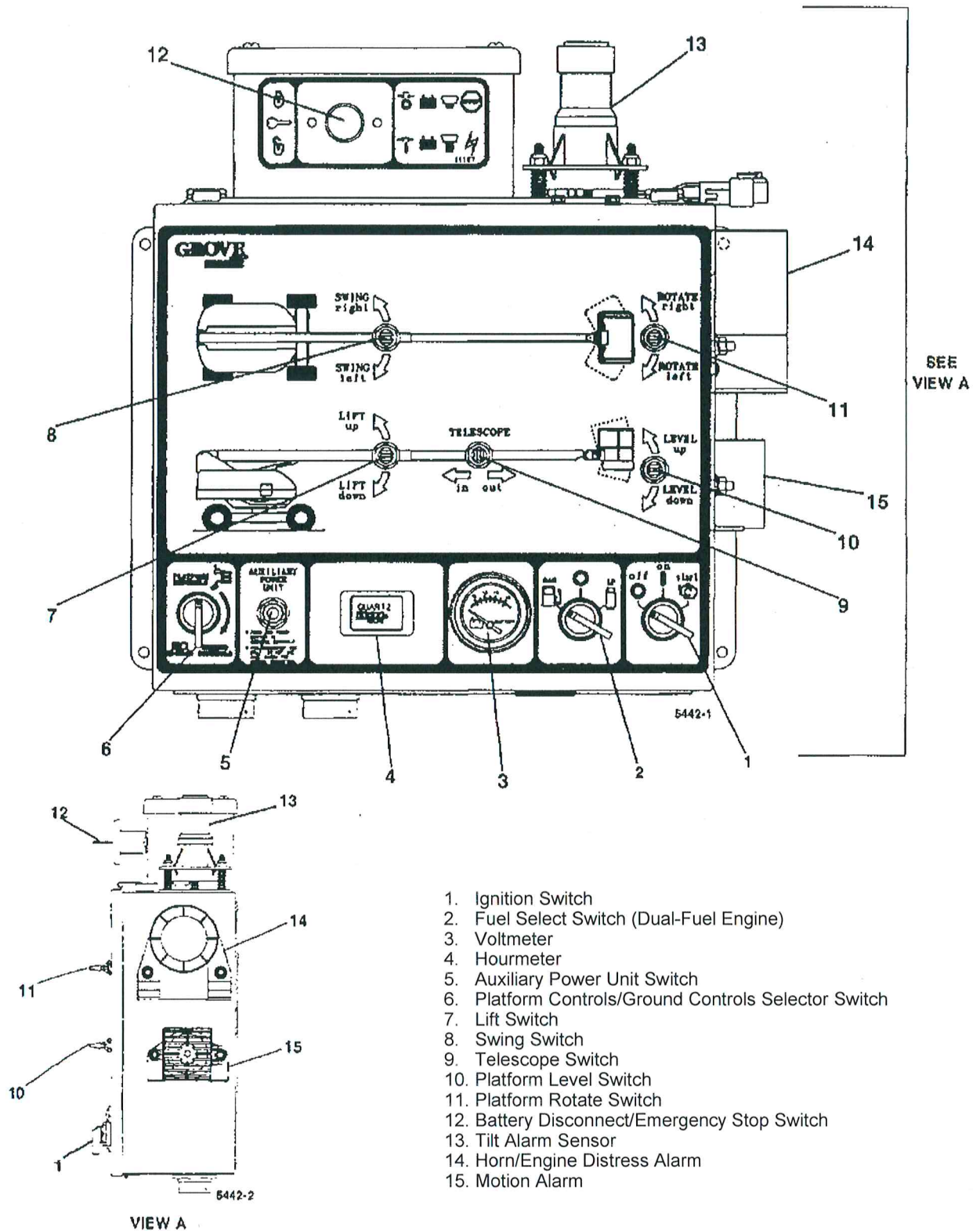

Ground Controls

- LEVEL UP - Position switch up
- LEVEL DOWN - Position switch down

PLATFORM ROTATE SWITCH

The platform ROTATE switch (11) is located on the right side of the ground controls. Position the switch in the direction of the arrows to LEFT or RIGHT to rotate the platform in the desired direction—a maximum of 90° from the center position.

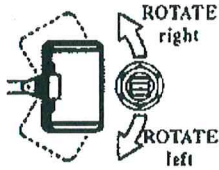

- ROTATE RIGHT - Position switch up
- ROTATE LEFT - Position switch down

OTHER CONTROLS

BATTERY DISCONNECT/EMERGENCY STOP SWITCH

The key-lock BATTERY DISCONNECT switch (12) is mounted on the left side of the work platform above the ground controls. It has two positions—locked and unlocked.

- When the key is in key position #2, the switch is locked.
- When the key is in key position #1, you can remove the key. The switch will lock in the OFF position after you actuate a function.

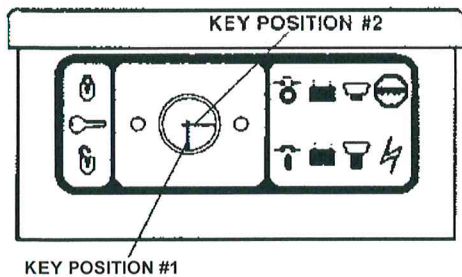

Push the BATTERY DISCONNECT/EMERGENCY STOP switch to:

- Remove all DC electrical power from the machine
- Stop the engine and all work platform functions

ALARMS

HORN/ENGINE DISTRESS ALARM AND MOTION ALARM

These (14 and 15)—located on the right side panel of the ground controls—will sound if:

- The engine is started
- Any function is activated
- The PLATFORM CONTROLS/ GROUND CONTROLS selector switch is positioned to GROUND CONTROLS it is also activated by either the engine oil pressure switch or the engine temperature switch—or a combination of the two.

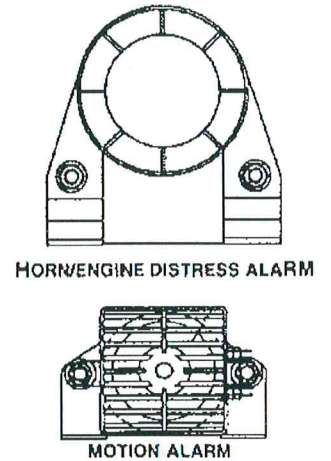

- The normally open oil pressure switch will close when pressure falls below 27.5 kPa/0.27 bar (4 psi).
- The normally open temperature switch will close when the temperature rises above 107°C±4°C (225°F±7°F) on the Ford engine. The V-belt failure switch, located next to the idler pulley, will activate if the V-belt fails on the Deutz engine.

TILT ALARM SENSOR

The tilt alarm sensor (13) is located on the left side of the work platform. It is mounted above the ground controls next to the BATTERY DISCONNECT/EMERGENCY STOP switch.

When the work platform is 5° off horizontal, the tilt sensor will:

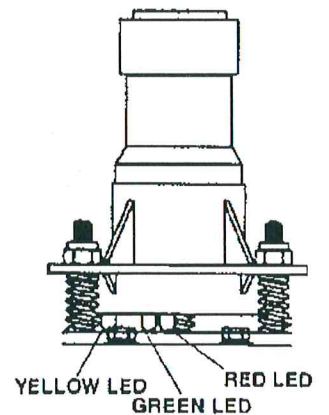

- Activate and sound the tilt buzzer located in the platform controls

- Illuminate the red tilt LED in the platform controls

When you first turn on the work platform's power, the tilt sensor will cause the tilt alarm buzzer to chirp. This test makes sure the tilt sensor is functional.

Three LEDs are located underneath the tilt sensor:

- Green LED - When this LED is lit, the tilt sensor has power and is ready to operate,
- Yellow LED — This LED lights up when the

work platform reaches the 5° trip point.

- Red LED - This LED lights up when the work platform reaches the 5° trip point. It turns off after a two-second time delay and sounds the tilt alarm buzzer.

The work platform is in an unstable condition when the tilt alarm activates. Do not perform any functions-except those necessary to safely relocate the work platform-until the work platform is on level ground. The tilt alarm will only function when the ground controls IGNITION switch is in the ON position.

SECTION 4

OPERATING PROCEDURES

PRE-STARTING CHECKS

DANGER

FAILURE TO PROPERLY SERVICE, MAINTAIN, AND INSPECT THIS MACHINE COULD RESULT IN DEATH OR SERIOUS INJURY. THIS MACHINE MUST NOT BE USED UNLESS IT IS OPERATING PROPERLY.

Always perform a complete walk-around visual inspection of the work platform. Pay special attention to:

- Structural damage
- Loose equipment
- Leaks
- Other conditions that would require immediate correction for safe operation

The following checklist items will help you safely prepare the work platform before you start work.

FUEL SUPPLY

If a dual-fuel or diesel engine is installed, fill fuel tank. Place cap on tightly.

On dual-fuel machines, check for leaks in LP-gas tanks/lines. Secure mounting straps tightly.

DANGER

LP GAS IS VOLATILE AND CAN BURN SKIN AND EYES. FAILURE TO FOLLOW PROPER PROCEDURES WHEN CONNECTING AND DISCONNECTING THE LP-GAS TANK COULD RESULT IN SERIOUS INJURY OR DEATH. DO NOT SMOKE OR ALLOW OPEN FLAMES NEAR THE LP-GAS TANK. WEAR GLOVES AND KEEP ALL HOSES AND COUPLING FIXTURES DIRECTED AWAY FROM YOUR FACE WHEN CHANGING THE LP-GAS TANK.

ENGINE OIL

Check engine oil level in crankcase—either before starting engine or after engine has been stopped for more than five minutes. Determine final oil level by reading oil level marks on dipstick.

Refer to Section 5 - LUBRICATION in this handbook for proper oil level.

ENGINE COOLANT

DANGER

SHUT DOWN ENGINE AND ALLOW RADIATOR TO COOL. RADIATOR FLUID IS HOT AND UNDER PRESSURE.

Check coolant level in overflow tank. Fill to proper level.

Refer to Section 5 - LUBRICATION in this handbook for proper fluid level.

BATTERY

Check state-of-charge indicator on battery' (if supplied). Make sure cables and clamps are tight and not corroded.

DAILY LUBRICATION

Service all components that require daily lubrication.

Refer to Section 5 - LUBRICATION in this handbook for proper lubrication amounts.

TIRES

DANGER

SUBSTITUTION OR REPLACEMENT OF FOAM-FILLED TIRES WITH PNEUMATIC (AIR-FILLED) TIRES WILL ALTER MACHINE STABILITY AND COULD RESULT IN SERIOUS INJURY OR DEATH. FOAM-FILLED TIRES ARE HEAVIER THAN PNEUMATIC TIRES. BE CAREFUL WHEN REMOVING THE TIRE/WHEEL ASSEMBLY.

DANGER

ONCE THE TIRE/WHEEL ASSEMBLY IS FILLED WITH FOAM, IT IS BONDED TOGETHER. IF EITHER PIECE BECOMES DAMAGED OR WORN, YOU MUST REPLACE THE COMPLETE ASSEMBLY.

Check for severe cuts and foreign objects embedded in treads. Check tire inflation decal for correct inflation pressure. Check foam-filled tire decal for foam-fill specifications.

HYDRAULIC RESERVOIR AND FILTER

Check hydraulic fluid quantity level. Check filter condition indicator and breather for cleanliness and security.

Refer to Section 5 - LUBRICATION in this handbook for proper hydraulic fluid level.

TILT ALARM

Check tilt alarm system daily. Press down on one corner of tilt sensor (located on left side of work platform frame on top of the ground controls) to test for proper functioning. If the buzzer in the platform controls sounds, the system is functioning properly.

CONTROL OPERATION

1. Verify the operation of the auxiliary power unit on both the platform controls and the ground controls by briefly actuating the APU switch and activating each switch and/or controller on the platform controls.
2. Verify the operation of the controllers and the toggle switches on the platform controls.

CAUTION

WHEN TESTING FUNCTIONS AND MONITORING THE RELAY BOARD IN THE GROUND CONTROLS, THE EMERGENCY STOP SWITCH IN THE PLATFORM CONTROLS MUST BE PULLED OUT AND THE KEY-OPERATED IGNITION SWITCH IN THE GROUND CONTROLS MUST BE

TURNED TO THE ON POSITION. DO NOT START THE ENGINE OR ACTIVATE AUXILIARY POWER. DESIRED CONTROLS MAY THEN BE FUNCTIONED.

3. Verify the operation of each switch at the ground controls.

TURNTABLE LOCK PIN

Check the turntable lock pin position. Remove the turntable lock pin from its locked position and store it on the turntable before you start work platform operations.

Before traveling on uneven surfaces—and when transporting the work platform—place the turntable lock pin in the locked position.

AIR CLEANER

Check filter for cleanliness and tubing for proper installation.

WORK PLATFORM OPERATING TIPS

- The rated capacity shown on the decal in platform includes total weight of work platform occupant(s) and required tools to perform a desired task. Do not exceed this capacity.
- When the work platform is in the working position, shut down the engine.
- Do not let the work platform remain idle for long periods of time. At least once a week, start the work platform engine and cycle all functions several times.
- Work platforms are stable only when on level surfaces. Always locate the work platform on a firm level surface before raising the boom.
- When traveling from one work site to another, make sure the platform is as close to the ground as possible—while maintaining adequate clearance for terrain.
- In cold climates, you must actuate a function to circulate and warm the oil.

ENGINE OPERATION

DANGER

DURING OPERATION, GASOLINE, DIESEL, AND OTHER INTERNAL COMBUSTION ENGINES MAY GENERATE POTENTIALLY HAZARDOUS CONCENTRATIONS OF CARBON MONOXIDE OR OTHER BY-PRODUCTS OF COMBUSTION.

CARBON MONOXIDE IS ODORLESS. KEEP WORK AREA WELL VENTILATED. ATMOSPHERES THAT DO NOT CONTAIN SUFFICIENT OXYGEN CAN CAUSE DIZZINESS, UNCONSCIOUSNESS, OR EVEN DEATH. RAPID ASPHYXIATION AND/OR HYPOXIA MAY OCCUR IN CONFINED AREAS THAT DO NOT HAVE ADEQUATE VENTILATION.

FOR EXTENDED PERIODS OF WORK PLATFORM USAGE INDOORS, GENERAL DILUTION AND/OR LOCAL EXHAUST VENTILATION SHOULD BE USED TO MAINTAIN EXPOSURE LIMITS (PELS) OR THRESHOLD LIMIT VALUES (TLVS).

IF A PERSON BREATHES IN LARGE AMOUNTS OF CARBON MONOXIDE OR OTHER EXHAUST FUMES, MOVE THE EXPOSED PERSON TO FRESH AIR AT ONCE.

IF BREATHING BECOMES DIFFICULT, PERFORM ARTIFICIAL RESPIRATION. KEEP THE AFFECTED PERSON WARM AND AT REST. GET MEDICAL ATTENTION AS SOON AS POSSIBLE.

CAUTION

ON LP-GAS ENGINES, PLACE IGNITION SWITCH IN OFF POSITION WHEN ENGINE IS NOT RUNNING. UNUSED LP GAS MAY ACCUMULATE IF SWITCH IS NOT TURNED OFF.

Starting and shut down procedures for most engines generally follow the same pattern. The following procedures can be applied except where specific differences are noted. Refer to applicable engine manufacturer's service manual for detailed procedures.

STARTING PROCEDURE (DUAL-FUEL AND DIESEL ENGINES)

CAUTION

NEVER CRANK ENGINE FOR MORE THAN 10 SECONDS DURING AN ATTEMPTED START. IF ENGINE FAILS TO START AFTER 10 SECONDS, LET STARTER MOTOR COOL FOR APPROXIMATELY TWO MINUTES BEFORE ATTEMPTING ANOTHER START.

CAUTION

IF ENGINE FAILS TO START AFTER FOUR ATTEMPTS, CORRECT WHATEVER IS CAUSING MALFUNCTION BEFORE ATTEMPTING ANY FURTHER STARTS.

1. Position keyed IGNITION switch on ground controls to ON.

DANGER

DEATH OR SERIOUS INJURY COULD RESULT FROM FALLING OUT OF PLATFORM. DO NOT OPERATE WORK PLATFORM UNLESS ALL PLATFORM RAILINGS ARE IN PLACE AND SECURE. AN ADEQUATE FALL PROTECTION DEVICE (WITH LANYARD ATTACHED) MUST BE WORN BY ALL PERSONNEL OCCUPYING THE PLATFORM. CLOSE ALL GATES AND OPENINGS. MAINTAIN A FIRM FOOTING ON PLATFORM FLOOR AT ALL TIMES.

NOTE

A start delay timer (which is part of the start circuit) aids in preventing anti-restart.

2. Enter platform and close gate.

3. Install an adequate fall protection device (body harness) and attach lanyard to platform lanyard attachment handle.
4. Pull out EMERGENCY STOP switch.
5. Push START switch on platform controls to start the engine.

COLD-WEATHER STARTING

Use the correct grade of oil (for the prevailing temperature) in the crankcase to prevent hard cranking. The automatic choke for the gasoline engine is sufficient for starting the gasoline engine in cold weather.

For cold-weather starting procedures on the Ford dual-fuel engine, refer to the Ford Sendee Operation and Maintenance Manual.

For cold-weather starting procedures on the Deutz diesel engine, refer to the Deutz Service Operation Manual.

SHUTDOWN PROCEDURE

CAUTION

IDLE GASOLINE AND LP-GAS ENGINES FOR 30 SECONDS BEFORE TURNING ENGINE OFF. IF YOU DO NOT IDLE, A BACKFIRE CAN OCCUR.

1. Idle engine to lower its temperature before stopping.
2. Push in EMERGENCY STOP switch on platform controls to remove all electrical power from controls.
3. Position IGNITION switch at ground controls to OFF (vertical position).

DUAL-FUEL OPERATION

DANGER

LP GAS IS VOLATILE AND CAN CAUSE BURNS TO SKIN AND EYES. FAILURE TO FOLLOW PROPER PROCEDURES WHEN CONNECTING AND DISCONNECTING LP-GAS TANK COULD RESULT IN DEATH OR SERIOUS INJURY.

DANGER

DO NOT SMOKE OR ALLOW OPEN FLAMES NEAR ANY FUEL TANK.

NOTE

Refer to service manual for LP-gas tank removal procedures.

NOTE

When transferring fuels, put FUEL SELECT switch in neutral position until engine begins to miss. Then throw switch to selected fuel position.

Converting from Gasoline to LP Gas

1. Run gasoline carburetor dry with the FUEL SELECT switch (located on the bottom right side of the ground controls) in the neutral position.
2. When the engine stops, move FUEL SELECT switch to the L.P. position and restart the engine.

Converting from LP Gas to Gasoline

1. Allow the engine to run on LP gas. Position the FUEL SELECT switch to the neutral position.
2. When the engine stops, position the FUEL SELECT switch to the GAS position and restart the engine.
3. The engine (in order to fill the carburetor float bowl with gasoline) may take extended cranking before it starts. Do not crank for more than 10 seconds continuously.

EMERGENCY STOP

NOTE

Pushing in on the EMERGENCY STOP switch on the platform controls removes all electrical power from the controls - stopping the engine and all work platform functions.

NOTE

The EMERGENCY STOP switch controls the electrical circuit to the IGNITION switch.

1. Push in EMERGENCY STOP switch on platform controls to stop engine and remove all electrical power from controls.
2. Position ground controls IGNITION switch to OFF (vertical position).
3. Pull out EMERGENCY STOP switch to reset.

CAUTION

BEFORE ATTEMPTING TO RESTART THE ENGINE, CORRECT ANY PROBLEM(S) THAT CAUSED EMERGENCY SHUT DOWN.

WORK PLATFORM TRAVEL OPERATION

TRAVELING-GENERAL

DANGER

BEWARE OF CONDITIONS THAT COULD ADVERSELY AFFECT MACHINE STABILITY. DEATH OR SERIOUS INJURY COULD RESULT FROM TIP-OVER.

DANGER

PRIOR TO ANY OPERATION, INSPECT ENTIRE WORK SITE AND ALL GROUND CONDITIONS WHERE WORK PLATFORM WILL TRAVEL DURING OPERATION.

DANGER

MAKE SURE LOAD ON PLATFORM IS SECURE AND EVENLY DISTRIBUTED.

DANGER

DO NOT POSITION WORK PLATFORM NEAR HOLES OR DROP-OFFS.

DANGER

OPERATE WORK PLATFORM ON FIRM LEVEL SURFACES. DO NOT DRIVE WORK PLATFORM INTO HOLES, CURBS, OR OTHER OBSTACLES ON GROUND WHICH MIGHT SUBJECT WORK PLATFORM TO UNDUE STRESSES OR POSSIBLE OVERTURN.

DANGER

DO NOT OPERATE WORK PLATFORM IF WIND SPEED EXCEEDS 32 KM/H (20 MPH).

CAUTION

MAKE SURE ANY OPTIONAL HYDRAULIC/ELECTRICAL POWER SWITCHES TO PLATFORM ARE IN OFF POSITION BEFORE DRIVING WORK PLATFORM.

CAUTION

MAKE SURE TRAVELING SURFACES HAVE A SLOPE OF LESS THAN 5° AND WILL SUPPORT A LOAD GREATER THAN THE WORK PLATFORM'S WEIGHT.

EMERGENCY TOWING

CAUTION

SHOULD WORK PLATFORM BECOME MIRED DOWN, USE A TOW TRUCK OR TRACTOR TO FREE VEHICLE. SEVERE DAMAGE TO DRIVE SYSTEM COMPONENTS MAY OCCUR IF OPERATOR ATTEMPTS TO FREE WORK PLATFORM UNASSISTED.

CAUTION

BEFORE TOWING WORK PLATFORM, THE DISCONNECT CAP ON THE TORQUE HUB MUST BE POSITIONED FOR STOWING (DIMPLES IN). TOWING IS LIMITED TO EXTREMELY SHORT DISTANCES AT A MAXIMUM

SPEED OF 4.8 KM/H (3 MPH), SEVERE DAMAGE TO THE DRIVE SYSTEM MAY RESULT IF TOWING IS OTHERWISE ACCOMPLISHED.

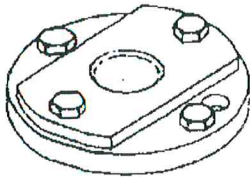

4706-1

Dimpled Centers Inward
{Emergency Towing}

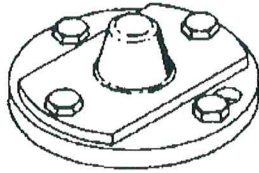

4706-2

Dimpled Centers Outward
(Normal Operation)

There are two tiedown/emergency tow lugs installed on each end of the work platform. When using these lugs, always tow or pull using both lugs.

EXTENDED TRAVEL

1. Lower the boom.
2. Retract the boom and lower to horizontal. The jib may be elevated to improve visibility (if applicable).
3. Insert the turntable lock pin.
4. Physically navigate the route of travel prior to moving the work platform.
5. Properly orient turntable for intended route of travel.
6. Always post a lookout when operator's view is obstructed.

DANGER

DEATH OR SERIOUS INJURY COULD RESULT FROM CRUSHING OR OTHER EXTERNAL CONTACTS. BE AWARE OF CONTACT WITH OBJECTS EXTERNAL TO PLATFORM.

DANGER

BE AWARE OF SURROUNDINGS AT ALL TIMES WHILE DRIVING THE MACHINE. DO NOT POSITION PLATFORM INTO OVERHEAD OBSTRUCTIONS. DO NOT DRIVE ANY PART OF

WORK PLATFORM INTO CONTACT WITH EXTERNAL OBJECTS.

7. Make sure clearances and/or overhead obstructions have been considered prior to work platform movement.

DANGER

THIS MACHINE IS NOT INSULATED. DEATH OR SERIOUS INJURY COULD RESULT FROM CONTACT WITH OR INADEQUATE CLEARANCE FROM ELECTRICAL POWER LINES OR EQUIPMENT.

DANGER

DO NOT OPERATE ANY PART OF THIS MACHINE IN PROXIMITY TO ELECTRICAL POWER LINES OR EQUIPMENT. MAINTAIN A MINIMUM CLEARANCE OF 6 M (20 FEET) FROM ALL ELECTRICAL POWER LINES OR EQUIPMENT.

8. Avoid routes that may place work platform near overhead energized power sources.

CAUTION

GRADEABILITY IS A THEORETICAL VALUE WHICH INDICATES THE MAXIMUM SLOPE THAT A MACHINE HAS BEEN DESIGNED TO NEGOTIATE STRAIGHT UP AND DOWN IN LINE WITH THE SLOPE IN THE FORWARD OR REVERSE DIRECTION WITH THE MACHINE IN THE TRAVEL CONFIGURATION. GRADEABILITY IS EXPRESSED AS A PERCENTAGE.

9. The work platform must be mechanically assisted when traveling grades exceeding the percentages shown on the table title *Theoretical Gradeability*.

THEORETICAL GRADEABILITY	
MODEL	GRADEABILITY
T60 (MZ66)	30 %
T60XT (MZ66XT)	50 %

10. If distance to be traveled on grades exceeds a few hundred meters (feet), transport work platform on a low-boy trailer. Refer to Section 6 - TRANSPORTATION INSTRUCTIONS in this handbook.

MOVING THE WORK PLATFORM (SHORT DISTANCE OR WORK MODE)

DANGER

BEWARE OF CONDITIONS THAT COULD ADVERSELY AFFECT MACHINE STABILITY. DEATH OR SERIOUS INJURY COULD RESULT FROM TIP-OVER. PRIOR TO ANY OPERATION, INSPECT ENTIRE WORK SITE AND ALL GROUND CONDITIONS WHERE WORK PLATFORM WILL TRAVEL DURING OPERATION.

DANGER

OPERATE WORK PLATFORM ONLY ON FIRM LEVEL SURFACES. DO NOT POSITION WORK PLATFORM NEAR HOLES OR DROP-OFFS. DO NOT DRIVE WORK PLATFORM INTO HOLES, CURBS, OR OTHER OBSTACLES ON GROUND.

DANGER

DEATH OR SERIOUS INJURY COULD RESULT FROM CONTACT WITH OR INADEQUATE CLEARANCE FROM ELECTRICAL POWER LINES OR EQUIPMENT. DO NOT OPERATE ANY PART OF THIS MACHINE IN PROXIMITY TO ELECTRICAL POWER LINES OR EQUIPMENT. MAINTAIN A MINIMUM CLEARANCE OF 6 M (20 FEET) FROM ALL ELECTRICAL POWER LINES OR EQUIPMENT.

DANGER

DO NOT OPERATE THIS MACHINE UNLESS YOU ARE QUALIFIED BY TRAINING EXPERIENCE IN THE SAFE OPERATION OF THIS MACHINE. TRAINING INCLUDES COMPLETE KNOWLEDGE OF YOUR EMPLOYER'S WORK RULES, THE OPERATOR'S

AND SAFETY HANDBOOK, AND ALL GOVERNMENTAL REGULATIONS RELATIVE TO THIS MACHINE. AN UNTRAINED OPERATOR SUBJECTS HIMSELF AND OTHERS TO DEATH OR SERIOUS INJURY.

DANGER

DEATH OR SERIOUS INJURY COULD RESULT FROM FALLING OUT OF THE PLATFORM. DO NOT OPERATE WORK PLATFORM UNLESS ALL PLATFORM RAILINGS ARE IN PLACE AND SECURE AS ADEQUATE FALL PROTECTION DEVICES ARE REQUIRED DURING OPERATION OF PLATFORM. MAINTAIN A FIRM FOOTING ON PLATFORM FLOOR AT ALL TIMES.

DANGER

DO NOT OPERATE WORK PLATFORM IF WIND SPEED EXCEEDS 32 KM/H (20 MPH).

CAUTION

THIS PLATFORM IS INTENDED TO BE USED IN HEAVY AND LIGHT INDUSTRIAL-, COMMERCIAL-, AND LEISURE-TYPE ENVIRONMENTS. OPERATION OF THE PLATFORM IN CLOSE PROXIMITY TO HIGH-POWERED RADIO TRANSMISSION APPARATUS (HOSPITALS, AIRPORTS, MARINE LOCATIONS) MAY AFFECT ONE OR MORE FUNCTIONS OF THE PLATFORM.

NOTE

The work platform may be moved short distances (from work station to work station) with the platform elevated provided the work platform remains on a firm level surface.

1. Properly orient turntable for intended direction of travel.
2. Depress FOOTSWITCH to enable controls.

3. Position the ENGINE THROTTLE SPEED switch to HIGH or LOW and the FUNCTION SPEED switch to LOW, TORQUE, or HIGH.
4. Move the DRIVE controller slowly in the intended direction of travel. Move controller forward (FWD) away from the operator to drive forward or rearward (REV) toward the operator to drive in reverse.
5. At next work station, return the DRIVE controller to neutral and shut down the engine when the work platform is in the desired position.

BOOM LOWERED AND BOOM RETRACTED LIMIT SWITCHES

The boom retracted limit switch is installed at the rear of the boom base section. The boom lowered limit switch is installed on the rear of the turntable beneath the boom base section.

When the boom is extended, the boom retracted limit switch closes and only low drive is attainable. When the boom is raised 30.4 cm (12 inches) from the bottom rest, the boom lowered limit switch opens and only low will be attainable. To reduce engine noise, all functions can be operated at low engine throttle.

FUNCTION SPEED SWITCH

The FUNCTION SPEED toggle switch can be positioned to either the HIGH OR LOW position and that speed will be obtained.

When the boom is extended or the platform is elevated above +2°, the high speed drive is cutout and only the low speed mode is attainable. To reduce engine noise, all functions can be operated at low engine throttle.

STEERING

DANGER

IF THE PLATFORM IS AT THE FORWARD END (AS SHOWN BY THE FORWARD DECALS) OF THE WORK PLATFORM, THE STEERING AND DRIVE CONTROLS WILL BE REVERSED.

NOTE

The normal steering configuration of the work platform is the boom over the rear and the operator in the platform facing the forward direction.

NOTE

The forward (FWD) direction is indicated by the black arrow. The reverse direction (REV) is indicated by the white arrow.

Steering is accomplished as follows:

1. Depress the FOOTSWITCH to enable the controls.
2. Position the STEER SELECT switch to FRONT or REAR.
3. Press the left side of the THUMB STEER switch (on top of the DRIVE controller) to steer to the left or the right side of the THUMB STEER switch (on top of the DRIVE controller) to steer to the right.

TRAVELING

CAUTION

DO NOT ALLOW PLATFORM TO COME IN CONTACT WITH THE GROUND OR OBJECTS ON THE GROUND. EQUIPMENT DAMAGE MAY OCCUR.

NOTE

The forward direction is indicated by the black arrow. The reverse direction is indicated by the white arrow.

FORWARD

1. After the engine has warmed up, depress the FOOTSWITCH to enable the controls. Position the THROTTLE SPEED switch to LOW or HIGH and the FUNCTION SPEED switch to LOW, TORQUE, or HIGH.
2. Move the DRIVE controller slowly away from the operator to drive forward (FWD).

STOPPUNG

Stopping is accomplished by slowly returning the DRIVE controller to the neutral position. The brakes will apply automatically.

REVERSE

Traveling in reverse is accomplished the same way as traveling forward except for positioning the DRIVE controller toward the operator to reverse (REV). Refer to TRAVELING - Forward in this section.

GENERAL WORK PLATFORM OPERATION

GROUND CONTROLS

DANGER

DO NOT OPERATE WORK PLATFORM UNLESS ALL CONTROLS ARE FUNCTIONING PROPERLY.

DANGER

OPERATE GROUND CONTROLS ONLY WHEN PLATFORM IS UNOCCUPIED OR WHEN OPERATOR IS UNABLE TO USE PLATFORM CONTROLS. FAILURE TO DO SO MAY RESULT IN DEATH OR SERIOUS INJURY.

DANGER

USE EXTREME CAUTION WHEN OPERATING WORK PLATFORM FROM GROUND CONTROLS. IF IT IS NECESSARY TO USE GROUND CONTROLS WHEN PLATFORM IS OCCUPIED, OBTAIN PERMISSION FROM PLATFORM OCCUPANT (WHENEVER POSSIBLE) BEFORE DOING SO.

NOTE

When the platform is occupied, use the ground controls in emergency situations only.

NOTE

Check ground controls every day prior to work platform operation. The ground controls are located on the left side of the work platform.

If the engine is running, operate the ground controls as follows:

1. If possible, inform platform occupant(s) of your intent to use the ground controls.
2. Position PLATFORM CONTROLS/GROUND CONTROLS selector switch to GROUND CONTROLS.
3. Actuate remaining switches to achieve desired work platform function.

If the engine is not running, operate the ground controls as follows:

1. If possible, inform platform occupant(s) of your intent to use the ground controls.
2. Position and hold the PLATFORM CONTROLS/GROUND CONTROLS selector switch to GROUND CONTROLS.
3. Start the engine using the ground controls IGNITION switch.
4. Actuate remaining switches to achieve desired work platform function.

EMERGENCY OPERATION (AUXILIARY POWER UNIT)

DANGER

THE AUXILIARY POWER UNIT SHOULD BE USED IN EMERGENCY SITUATIONS ONLY. THE AUXILIARY POWER UNIT PROVIDES AN AUXILIARY MEANS OF LOWERING, RETRACTING, AND ROTATING THE PLATFORM IN THE EVENT OF PRIMARY POWER LOSS. ALTHOUGH OTHER FUNCTIONS CAN BE SELECTED, THE AUXILIARY POWER UNIT SHOULD BE USED ONLY FOR THE FUNCTIONS LISTED ABOVE.

NOTE

The footswitch does not have to be depressed to operate the AUXILIARY POWER UNIT.

The AUXILIARY POWER UNIT provides the power to operate the work platform in case of a primary power source failure. It is not designed for use as a normal means of operation. The power available is limited and continual use will lessen the unit's effectiveness if it is needed in an emergency situation.

To operate the AUXILIARY POWER UNIT, actuate the platform controls or ground controls AUXILIARY POWER UNIT switch to achieve the desired function. The speed of each function is greatly reduced when operating with the AUXILIARY POWER UNIT.

PRE-OPERATIONAL CHECK

DANGER

DO NOT OPERATE THIS MACHINE UNLESS YOU ARE QUALIFIED BY TRAINING EXPERIENCE IN THE SAFE OPERATION OF THIS MACHINE. TRAINING INCLUDES COMPLETE KNOWLEDGE OF YOUR EMPLOYER'S WORK RULES, THE OPERATOR'S AND SAFETY HANDBOOK, AND ALL GOVERNMENTAL REGULATIONS RELATIVE TO THIS MACHINE. AN UNTRAINED OPERATOR SUBJECTS HIMSELF AND OTHERS TO DEATH OR SERIOUS INJURY.

DANGER

DEATH OR SERIOUS INJURY COULD RESULT FROM BEING CRUSHED BY MOVING MACHINERY. CLEAR ALL PERSONNEL FROM THE COUNTERWEIGHT AND SUPERSTRUCTURE AREA BEFORE LOWERING THE BOOM OR ROTATING THE SUPERSTRUCTURE.

After work platform has been readied for service, perform an operational check of work platform functions as follows:

1. Raise and lower the boom.

2. Swing the boom right and left a minimum of 45°.
3. Telescope the boom in and out.

WORK PLATFORM FUNCTIONS

SWINGING THE BOOM

DANGER

DEATH OR SERIOUS INJURY COULD RESULT FROM BEING CRUSHED BY MOVING MACHINERY. CLEAR ALL PERSONNEL FROM COUNTERWEIGHT AND SUPERSTRUCTURE AREA BEFORE LOWERING BOOM OR ROTATING SUPERSTRUCTURE.

CAUTION

REMOVE TURNTABLE LOCK PIN BEFORE ATTEMPTING TO SWING.

To swing the boom:

1. Depress the FOOTSWITCH to enable the controls.
2. Position the THROTTLE SPEED switch to LOW or HIGH.
3. Position the FUNCTION SPEED switch to LOW, TORQUE, or HIGH.
4. Position the SWING controller in the direction of the arrows to the LEFT or the RIGHT.

NOTE

The swing brake is spring applied and hydraulically released.

ELEVATING AND LOWERING THE BOOM

Elevating the Boom

DANGER

DEATH OR SERIOUS INJURY COULD RESULT FROM CRUSHING OR OTHER EXTERNAL CONTACTS. BE AWARE OF YOUR SURROUNDINGS AT ALL TIMES WHILE ELEVATING

PLATFORM. DEATH OR SERIOUS INJURY COULD RESULT FROM CRUSHING, PINCHING, OR OTHER EXTERNAL CONTACTS.

1. Depress the FOOTSWITCH to enable the controls.
2. Position the THROTTLE SPEED switch to LOW or HIGH.
3. Position the FUNCTION SPEED switch to LOW, TORQUE, or HIGH.
4. Position the LIFT controller rearward toward the operator to UP until the boom reaches the desired elevation.

Lowering the Boom

DANGER

DEATH OR SERIOUS INJURY COULD RESULT FROM BEING CRUSHED BY MOVING MACHINERY. CLEAR ALL PERSONNEL FROM THE COUNTERWEIGHT AND SUPERSTRUCTURE AREA BEFORE LOWERING THE BOOM. DO NOT LOWER PLATFORM ONTO OBSTRUCTIONS FROM BELOW.

To lower the boom:

1. Depress the FOOTSWITCH to enable the controls.
2. Position the THROTTLE SPEED switch to LOW or HIGH.
3. Position the FUNCTION SPEED switch to LOW, TORQUE, or HIGH.
4. Position the LIFT controller forward away from the operator to DOWN until the boom reaches the desired elevation.

TELESCOPING THE BOOM

Extending the Boom

DANGER

DEATH OR SERIOUS INJURY COULD RESULT FROM CRUSHING OR

OTHER EXTERNAL CONTACTS. BE AWARE OF SURROUNDINGS AT ALL TIMES WHILE ELEVATING AND/OR EXTENDING THE BOOM.

To extend the boom:

1. Depress the FOOTSWITCH to enable the controls.
2. Position the THROTTLE SPEED switch to LOW or HIGH.
3. Position the FUNCTION SPEED switch to LOW, TORQUE, or HIGH.
4. Position the TELESCOPE controller rearward toward the operator to OUT.
5. Extend the boom to the desired length.

Retracting the Boom

DANGER

DEATH OR SERIOUS INJURY COULD RESULT FROM CRUSHING OR OTHER EXTERNAL CONTACTS. BE AWARE OF SURROUNDINGS AT ALL TIMES WHILE ELEVATING AND/OR EXTENDING THE BOOM.

To retract the boom:

1. Depress the FOOTSWITCH to enable the controls.
2. Position the THROTTLE SPEED switch to LOW or HIGH.
3. Position the FUNCTION SPEED switch to LOW, TORQUE, or HIGH.
4. Position the TELESCOPE controller forward away from the operator to retract the boom.

PLATFORM ROTATION

DANGER

DEATH OR SERIOUS INJURY COULD RESULT FROM BEING CRUSHED BY MOVING MACHINERY. CLEAR ALL PERSONNEL FROM COUNTERWEIGHT AND SUPERSTRUCTURE

AREA BEFORE LOWERING BOOM OR ROTATING SUPERSTRUCTURE.

DANGER

DEATH OR SERIOUS INJURY COULD RESULT FROM CRUSHING OR OTHER EXTERNAL CONTACTS. BE AWARE OF SURROUNDINGS AT ALL TIMES WHILE ROTATING PLATFORM. DO NOT POSITION PLATFORM INTO OVERHEAD OBSTRUCTIONS.

To rotate the platform:

1. Depress the FOOTSWITCH to enable the controls,
2. Position the PLATFORM ROTATE switch in the direction of the arrow to the LEFT or to the RIGHT. Rotation will stop when the switch is returned to the neutral position.

PLATFORM LEVELING

DANGER

DEATH OR SERIOUS INJURY COULD RESULT FROM CRUSHING OR OTHER EXTERNAL CONTACTS. BE AWARE OF SURROUNDINGS AT ALL TIMES WHILE ELEVATING AND LEVELING PLATFORM. DO NOT POSITION PLATFORM INTO OVERHEAD OBSTRUCTIONS.

DANGER

THE PLATFORM LEVEL MAY BE ADJUSTED WHEN THE BOOM IS IN ANY POSITION. DO NOT ADJUST THE PLATFORM WHILE OPERATING THE LIFT FUNCTION.

DANGER

THE PLATFORM IS SELF LEVELING, HOWEVER, IF MANUAL ADJUSTMENT IS REQUIRED, CAREFULLY ACTIVATE THE PLATFORM LEVELING SWITCH IN THE REQUIRED DIRECTION USING THE DIRECTION ARROWS. JOG SWITCH—DO NOT

HOLD. USE CAUTION IF YOU ARE STANDING IN THE PLATFORM WHILE LEVELING. IF THE PLATFORM IS STILL NOT LEVEL, THE LEVELING SYSTEM COMPONENTS SHOULD BE CHECKED BY A QUALIFIED MECHANIC AND THE PROBLEM CORRECTED BEFORE OPERATING THE WORK PLATFORM.

DANGER

DEATH OR SERIOUS INJURY COULD RESULT FROM BEING CRUSHED BY MOVING MACHINERY. CLEAR ALL PERSONNEL FROM THE COUNTERWEIGHT AND SUPERSTRUCTURE AREA BEFORE LOWERING THE BOOM. DO NOT LOWER THE PLATFORM ONTO OBSTRUCTIONS BELOW.

With the platform level and the boom in the 0° (horizontal) position, the platform should remain in the level position as the boom is raised or lowered. Platform leveling is accomplished with a master cylinder attached to the rear of the boom base section and the turntable weld and a slave cylinder attached to the rotator.

As the boom is elevated or lowered, the rod of the master cylinder extends or retracts. This action causes hydraulic fluid to extend or retract the slave leveling cylinder rod which will keep the platform level.

Purging the Leveling System

DANGER

REMOVE ALL LOOSE MATERIALS FROM THE PLATFORM. DO NOT ALLOW ANYONE TO REMAIN IN THE PLATFORM.

If the platform is level with the boom in the 0° (horizontal) position - but becomes out of level as it is raised - there is air in the leveling system. The air can be purged from the system using the following procedure:

1. Lower the boom.
2. Raise the platform at least one meter (three feet) from its fully down position to make sure the

platform does not hit the ground when put in the full tilt-down position.

3. Use the PLATFORM LEVEL switch on the ground controls to cycle the platform several times from full tilt-up position to full tilt-down position.
4. Elevate the boom. Make sure platform leveling system is operating properly.
5. If the platform is still not level, the leveling system components should be checked by a qualified mechanic. Correct any problems before operating the work platform. Refer to LEVELING CIRCUIT in Section 7 - PLATFORM in the service manual.

STOWING AND PARKING

DANGER

NEVER PARK WORK PLATFORM NEAR HOLES OR ON ROCKY OR EXTREMELY SOFT SURFACES. THIS MAY CAUSE WORK PLATFORM TO OVERTURN-RESULTING IN INJURY TO PERSONNEL AND DAMAGE TO WORK PLATFORM.

1. Position the work platform on a firm level surface.
2. Fully retract and lower the boom.
3. If possible, position the boom directly over the rear (travel position).
4. Engage the turntable lock pin.
5. Depress the EMERGENCY STOP switch on the platform controls.
6. Position the ground controls IGNITION switch to OFF.

7. Lock the access door to the ground controls (if possible).

PERFORMING WORK ON SHIPS, BARGES, AND OTHER FLOATING VESSELS

All Grove Worldwide Manlift® work platforms are designed, manufactured, tested, and intended for operation on firm level surfaces. Operation beyond these parameters is not recommended. Grove Worldwide, however, recognizes that on occasion the need arises to position an elevating work platform adjacent to or aboard a floating vessel when it may be the least hazardous and only practical way to perform a specific task.

Minimum recommendations for such use are:

- The work platform should only be used aboard floating vessels or perform work on floating vessels during periods of calm, still waters.
- When positioned aboard a floating vessel, the work platform shall be tied down or otherwise secured to the vessel's deck to maintain stability.
- Designate a lookout. Position lookout where he can continuously watch work platform operations and remain in direct communication with platform occupants. The lookout should warn of any potential conditions that could disrupt waters and cause vessel or work platform to move.
- If the calm water is disturbed by approaching waves, boats, etc.—or other adverse conditions exist—the work platform shall immediately be swung away and lowered or otherwise positioned to a safe location. Accordingly, the work platform must not be secured (i.e., tied off) or allowed to strike or impact another object or structure.
- When floating vessels are in open seas or unprotected harbors, do not use the work platform on board the vessel to position personnel at elevated locations.

NOTES

SECTION 5 LUBRICATION

Follow designated lubrication procedures to ensure maximum work platform lifetime and use. The procedures and lubrication chart in this section provide information on the types of lubricants used, the location of lubrication points, the frequency intervals for lubrication, and other important material.

LUBRICATION SYMBOLS	
Symbol	Description
EP-MPG	Extreme pressure multipurpose grease (lithium soap base)
EP-3MG	Extreme pressure 3% moly grease
EPGL-5	Extreme pressure gear lubricant - 80W90
EO-15W40	Engine oil - reference engine manufacturer's manual
HYDO	Hydraulic oil
AFC	Antifreeze/coolant - check engine manufacturer's service manual
DFL	Dry film lubricant

LUBRICATION POINTS

Regular lubrication must be performed on all lubrication points. Normally, the frequency for lubrication is based on component operating time. The most efficient method for keeping track of lube intervals is to maintain a job log indicating machine usage. The log should include hourmeter readings which can be used to determine which lube points will require attention based on their readings. Other lubrication requirements must be performed on a time basis (i.e. weekly, monthly, etc.).

Check oil levels and perform lubrication only when the work platform is parked on a level surface in the transport position—and while the oil is cold (unless otherwise specified).

On plug-type check points, the oil level should be at the bottom edge of the check port.

All grease fittings are SAE STANDARD unless otherwise indicated. Grease non-sealed fittings until grease extrudes from the fitting. Twenty-eight grams (one ounce) of EP-MPG equals one pump on a standard 0.45 kg (one-pound) grease gun. Excessive lubrication on non-sealed fittings will not harm the fittings or components, but too little lubrication can lead to shorter component life.

Unless otherwise indicated, items not equipped with grease fittings (such as linkages, pins, levers, etc.) should be lubricated with oil once a week. Motor oil applied sparingly will provide the necessary lubrication and help prevent the formation of rust. An antiseize compound may be used if rust has not formed.

If rust or corrosion is present, the component must be thoroughly cleaned before applying lubricant.

Grease fittings that are worn and will not hold the grease gun (or those that have a stuck check ball) must be replaced.

Where wear pads are used, cycle the component and relubricate to ensure complete lubrication of the entire wearing surface.

The following items describe lubrication points and give the lube type, lube interval, lube amount, and application of each. Each lubrication point is numbered. This number corresponds to the index numbers shown on the figures titled *T60 (MZ66) Lubrication Chart* and *Lubrication Diagram*.

CAUTION

USE THE FOLLOWING LUBRICATION INTERVALS AS A GUIDELINE ONLY. FORMULATE ACTUAL LUBRICATION INTERVALS TO CORRESPOND TO CONDITIONS SUCH AS CONTINUOUS DUTY CYCLES AND/OR HAZARDOUS ENVIRONMENTS.

NOTE

Check all fluid levels at ambient temperature.

T60 (MZ66) / T60XT (MZ66XT) LUBRICATION CHART

LOCATION	LUBE TYPE	LUBE INTERVAL	LUBE AMOUNT	APPLICATION
1. King Pin Bearings	EP-MPG	Monthly	Until grease extrudes	1 grease fitting each bearing
2. Tie Rods and End Links	EP-MPG	Monthly	Until grease extrudes	1 grease fitting each end of tie rods
3. Steer Cylinder	EP-MPG	Monthly	Until grease extrudes	1 grease fitting each end of steer cylinders
4. Torque Hubs	EPGL-5	<p>Check monthly. Initially change oil after 50 hours of operation, then 1,000 hours - or one year - whichever comes first. Higher temperatures make it necessary to change oil more frequently.</p>	0.51 L (17 ounces)	<p>Turn torque hubs so that the oil plug is 2,54 cm (one inch) below hub centerline. Refer to figure titled <i>Torque Hub - Fill View</i></p>
5. Hydraulic Motors	HYDO	Clean yearly	System fill	Direct flow from hydraulic system
6. Wheel Bearings (Non-Drive Hubs)	EP-MPG	<p>Check every 1,000 hours or annually - whichever comes first. Severe operating conditions may make it necessary to repack bearings more frequently.</p>	N/A	<ol style="list-style-type: none"> 1. Remove dust cap, cotter pin, nut, and bearing. 2. Pack bearing with EP- MPG. 3. Install the bearing, nut, cotter pin, and dust cap. 4. Refer to figure titled <i>Non-Drive Hub</i>.
7. Swing Gear Box	EPGL-5	Monthly	N/A	N/A

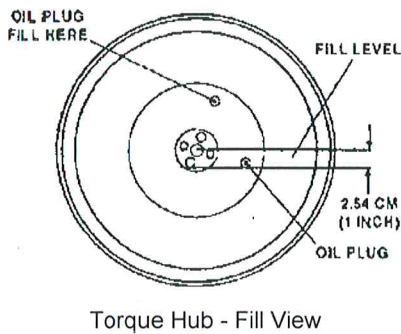

5405-5

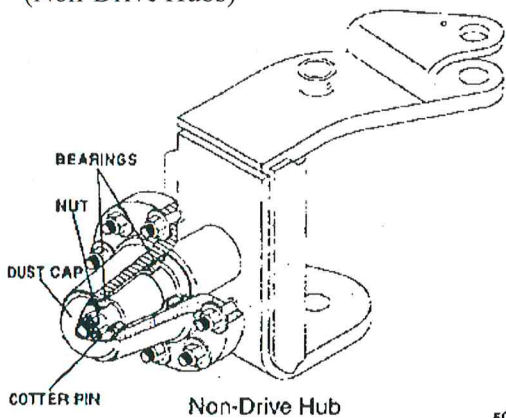

5090

T60 (MZ66) / T60XT (MZ66XT) LUBRICATION CHART

LOCATION	LUBE TYPE	LUBE INTERVAL	LUBE AMOUNT	APPLICATION
8. Swing Bearing Race	EP-MPG	Weekly	Until grease extrudes whole circumference of bearing	Apply grease to grease fittings located on inner race of bearing
9. External Gear	EP-3MG	Weekly	Coat all teeth	Brush on
10. Hydraulic Reservoir	HYDO	1. Check daily. 2. Drain as necessary.	136.2 L (36 gallons)	Fill through top of in-tank return filter
11. Oscillating Axle Pivot Pin (Optional)	EP-MPG	Monthly	Until grease extrudes	Grease fitting on pivot pin
12. Engine Crankcase	EO-15W/40	Check daily	Ford Engine 4.7 L (5 quarts)	Refer to applicable engine service manual. Final oil level to be established by use of the dipstick.
			Deutz Engine 7.76 L (14 quarts)	
Change Oil Interval - Ford Engine - After first 250 hours of operation Deutz Engine - After first 35 hours of operation and every 200 hours thereafter Refer to applicable engine service manual for more detailed information.				
13. Engine Coolant- Ford Engine	AFC	Check daily	As required	Refer to applicable engine service manual
14. Return Filter	Element Change Interval - Six months or more often under severe operating conditions			
15. Pressure Filter	Element Change Interval - Six months or more often under severe operating conditions			
16. Mid Section Wear Pads	Standard Models EP-MPG	Weekly	Thoroughly coat wear pad surface on fly sides	Standard Models - Brush on
	Hostile Environment Models DFL			Hostile Environment Models - Brush on. All surfaces must be properly cleaned and free from all dirt and grease before applying Dri-Slide lube. Agitate Dri-Slide lube per instructions on container before applying to all surfaces.

T60 (MZ66) / T60XT (MZ66XT) LUBRICATION CHART

LUBE INTERVAL	LUBE INTERVAL	LUBE INTERVAL	LUBE INTERVAL	LUBE INTERVAL
17. Base Section Wear Pads	Standard Models EP-MPG.	Weekly	Thoroughly coat wear pad surface on fly sides	Standard Models - Brush on
	Hostile Environment Models DFL			Hostile Environment Models - Brush on. All surfaces must be properly cleaned and free from all dirt and grease before applying Dri-Slide lube. Agitate Dri-Slide lube per instructions on container before applying to all surfaces.
18. Boom Telescope Cylinder Wear Pads	Standard Models EP-MPG	Weekly	Thoroughly coat wear pad surfaces inside top and bottom of fly section	Standard Models - Brush on
	Hostile Environment Models DFL			Hostile Environment Models - Brush on. All surfaces must be properly cleaned and free from all dirt and grease before applying Dri-Slide lube. Agitate Dri-Slide lube per instructions on container before applying to all surfaces.
19. Boom Base Section Top Plate	Standard Models EP-MPG	Weekly	Thoroughly coat inside only	Standard Models - Brush on
	Hostile Environment Models DFL			Hostile Environment Models - Brush on. All surfaces must be properly cleaned and free from all dirt and grease before applying Dri-Slide lube. Agitate Dri-SHde lube per instructions on container before applying to all surfaces.

T60 (MZ66) / T60XT (MZ66XT) LUBRICATION CHART

LUBE INTERVAL	LUBE INTERVAL	LUBE INTERVAL	LUBE INTERVAL	LUBE INTERVAL
20. Boom Mid Section Top Plate	Standard Models EP-MPG	Weekly	Thoroughly coat inside only	Standard Models - Brush on
	Hostile Environment Models DFL			Hostile Environment Models - Brush on. All surfaces must be properly cleaned and free from all dirt and grease before applying Dri-Slide lube. Agitate Dri-Slide lube per instructions on container before applying to all surfaces.
21. Boom Fly Section Bottom Plate	Standard Models EP-MPG	Weekly	Thoroughly coat outside only	Standard Models - Brush on
	Hostile Environment Models DFL			Hostile Environment Models - Brush on. All surfaces must be properly cleaned and free from all dirt and grease before applying Dri-Slide lube. Agitate Dri-Slide lube per instructions on container before applying to all surfaces.
22. Boom Mid Section Bottom Plates	Standard Models EP-MPG	Weekly	Thoroughly coat inside and outside only	Standard Models - Brush on
	Hostile Environment Models DFL			Hostile Environment Models - Brush on. All surfaces must be properly cleaned and free from ail dirt and grease before applying Dri-Slide lube. Agitate Dri-Slide lube per instructions on container before applying to all surfaces.

T60 (MZ66) / T60XT (MZ66XT) LUBRICATION CHART

LUBE INTERVAL	LUBE INTERVAL	LUBE INTERVAL	LUBE INTERVAL	LUBE INTERVAL
24. Boom Base Section Bottom Plate	Standard Models EP-MPG	Weekly	Thoroughly coat inside only	Standard Models - Brush on
	Hostile Environment Models DFL			Hostile Environment Models - Brush on. All surfaces must be properly cleaned and free from all dirt and grease before applying Dri-Slide lube. Agitate Dri-Slide lube per instructions on container before applying to all surfaces.

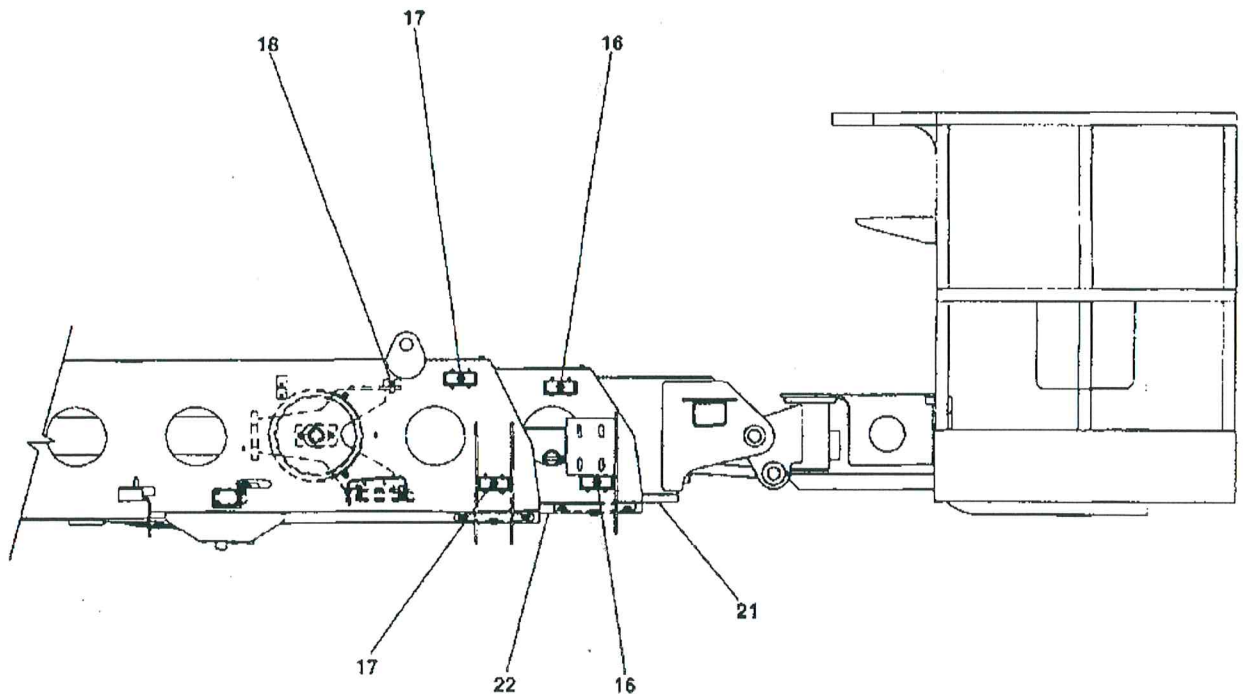

Lubrication Diagram (Sheet 1 of 3)

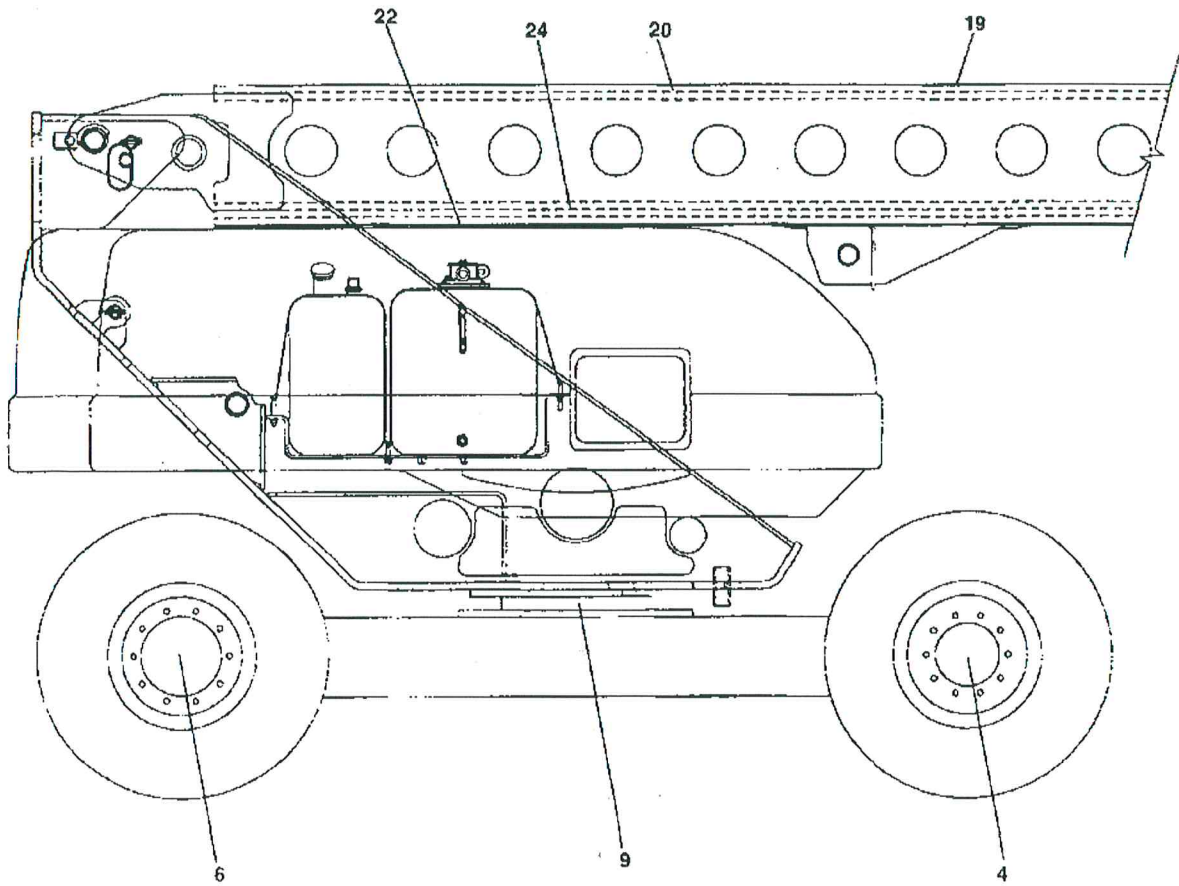

TWO-WHEEL DRIVE MODEL SHOWN

- | | |
|---|---------------------------------------|
| 1. King Pin Bearings | 13. Engine Coolant (Ford Engine) |
| 2. Tie Rod and End Links | 14. Return Filter |
| 3. Steer Cylinder Pivot Shafts | 15. Pressure Filter |
| 4. Torque Hubs | 16. Boom Mid Section Wear Pads |
| 5. Hydraulic Motors | 17. Boom Base Section Wear Pads |
| 6. Wheel Bearings (Non-Drive Hubs) | 18. Boom Telescope Cylinder Wear Pads |
| 7. Swing Gear Box | 19. Boom Base Section Top Plate |
| 8. Swing Bearing Race | 20. Boom Mid Section Top Plate |
| 9. External Gear | 21. Boom Fly Section Bottom Plate |
| 10. Hydraulic Reservoir | 22. Boom Mid Section Bottom Plate |
| 11. Oscillating Axle Pivot Pin (Optional) | 23. Boom Base Section Bottom Plate |
| 12. Engine Crankcase | |

Lubrication Diagram (Sheet 2 of 3)

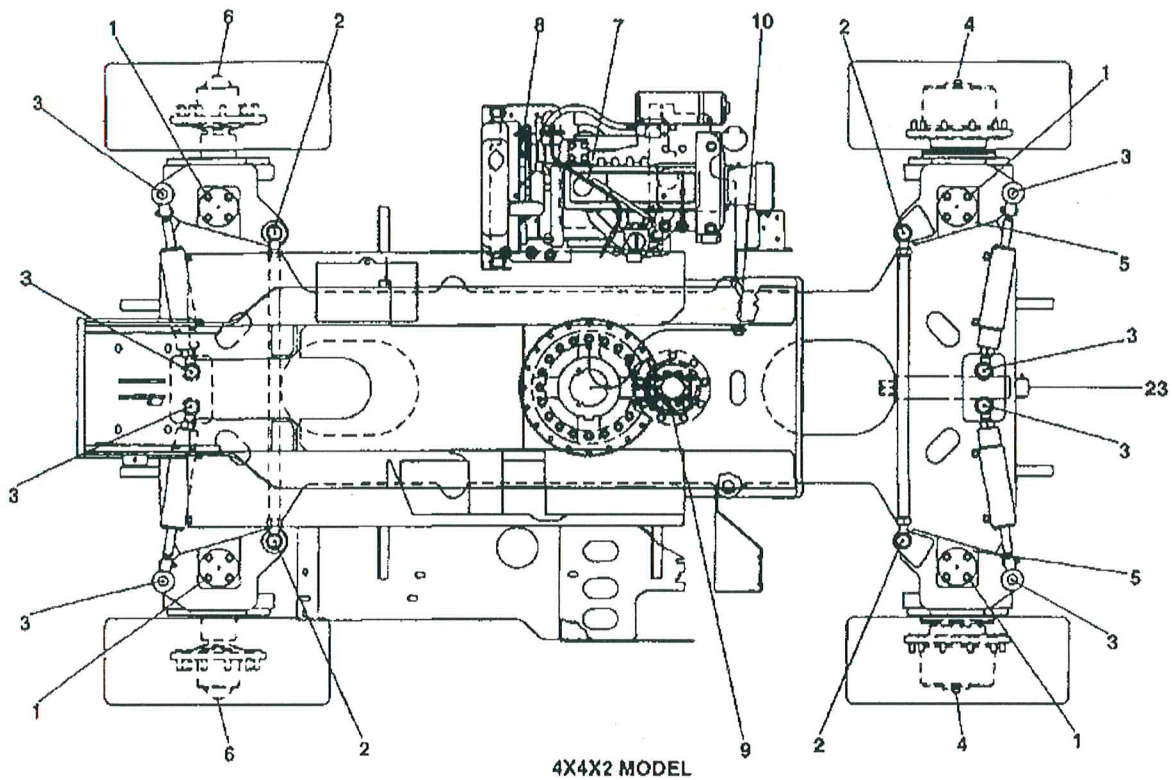

4X4X2 MODEL

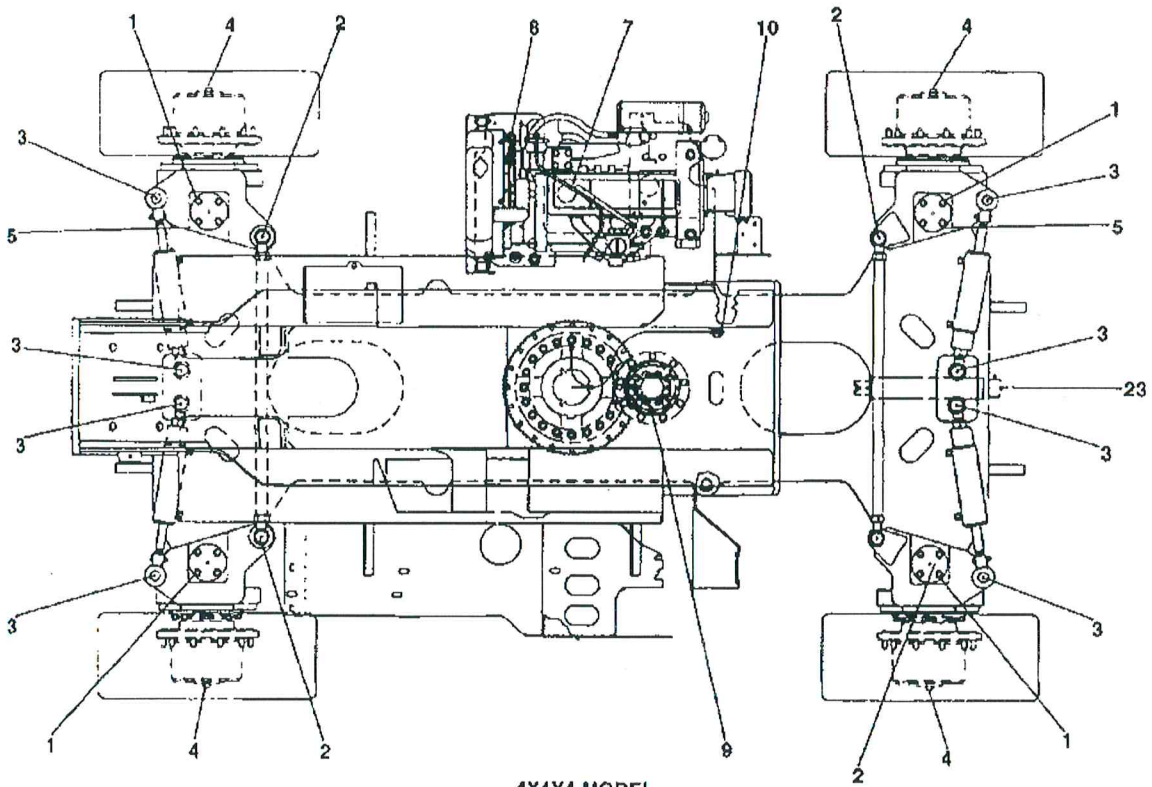

4X4X4 MODEL

Lubrication Diagram (Sheet 3 of 3)

SECTION 6

PRESSURE SETTINGS

Relief valves used in the work platform's hydraulic system protect the system from excessive pressure (within the circuit in which they are used) by returning hydraulic oil to the hydraulic reservoir when the pressure setting is exceeded.

You can determine the point at which a relief valve opens by placing a pressure gauge in the pressure test port or the main valve manifold. The needle on the pressure gauge will climb until it reaches the relief valve setting. At that point, the needle will stop climbing and fluctuate—indicating that the relief valve is open and returning hydraulic oil to the hydraulic reservoir.

Correct relief valve adjustment is mandatory if any hydraulic circuit is to function properly. Relief pressure settings must always be within established tolerances.

NOTE

Refer to the T60 (MZ66) / T60XT(MZ66 XT) Repair Manual (which can be purchased from Grove U.S. L.L.C. Lifetime Customer Support) for further information.

NOTE

Adjustment of relief valve pressure settings should only be performed—after the need for adjustment has been established—by qualified mechanics using the correct equipment.

NOTE

Check pressure settings prior to delivery of work platform and weekly thereafter.

The table titled *Relief Valve Pressure Settings* lists main and circuit relief valve pressure settings. If the pressure setting of any relief valve is not $\pm 5\%$ of the setting listed in the table, adjust the relief valve as necessary.

CAUTION

DO NOT OVERTIGHTEN THE ADJUSTMENT SCREW OR LOCKNUT.

CAUTION

DO NOT HOLD THE RELIEF VALVE OPEN FOR MORE THAN ONE MINUTE.

NOTE

To adjust a relief valve, turn the adjustment screw (in to increase or out to decrease) until the proper setting is reached.

RELIEF VALVE SETTINGS

NOTE

Check hydraulic valve pressures at the LSG port on the main valve manifold—except for drive circuit pressure and pump stand-by pressure. Check drive circuit pressure and pump stand-by pressure at the PG port on the main valve manifold. Check SAC pressure in line.

NOTE

Before checking relief valve pressures, properly adjust the controllers on the platform controls. Refer to the electrical section in the T60(MZ66)/T60XT(MZ66XT) Repair Manual (which can be purchased from Grove U.S. L.L.C. Lifetime Customer Support).

NOTE

The relief pressures read in the LSG port are 689.5 kPa/6.89 bar (± 100 psi).

PREPARATION

NOTE

Before setting pressures, warm the hydraulic oil to 75°F to 125°F.

NOTE

Use a 0 to 34,475 kPa/345 bar (0 to 5,000 psi) pressure gauge when adjusting the relief valves.

NOTE

When adjusting the relief valves, function the machine from the platform controls.

NOTE

After you have checked the controller adjustment, you should check pump stand-by pressure. Then proceed with checking the relief pressures.

CHECKING SYSTEM PRESSURE

1. Disconnect and cap the hydraulic lines to the brakes.
2. Remove the cap from the PG pressure test port.
3. Install the pressure gauge.
4. From the platform controls, position the THROTTLE SPEED and FUNCTION SPEED switches to HIGH.
5. Move the DRIVE controller momentarily in either direction. If the system pressure reading is not $\pm 1,292.81$ kPa/12.928 bar (187.5 psi) of 25,856.25 kPa/258.56 bar (3,750 psi), consult your local Grove® Manlift® distributor for servicing.
6. Shut down the engine.
7. Remove the pressure gauge.
8. Install the PG pressure test port cap.
9. Connect the hydraulic lines to the brakes.

CHECKING PUMP STAND-BY PRESSURE

1. Remove the cap from PG pressure test port.
2. Install the pressure gauge.
3. Start the engine.
4. Note the reading on the pressure gauge. If the reading is not 3,275.12 kPa/32.75 bar (475 psi), adjust the pressure setting as necessary.

CIRCUIT RELIEF VALVE ADJUSTMENT

SAC PORT PRESSURE (PR1)

1. Install the pressure gauge at the engine throttle cylinder.
2. Start the engine.
3. Operate any functions to activate engine high throttle.
4. Note the maximum reading on the pressure gauge. If the reading is not $\pm 51,71$ kPa/ 0.517 bar (7.5 psi), adjust the pressure setting as necessary.
5. Shut down the engine.
6. Remove the pressure gauge

PLATFORM ROTATE (PR2)

1. Remove the cap from the LSG port.
2. Install the pressure gauge.
3. Position the PLATFORM ROTATE switch to LEFT or RIGHT. Note the maximum reading on the pressure gauge. If the reading is not ± 965 kPa/9.6 bar (140 psi) of the relief pressure shown on the table titled *Relief Valve Pressure Settings*, adjust the pressure setting as necessary.
4. Shut down the engine.
5. Remove the pressure gauge.
6. Install the cap from the LSG port.

PLATFORM LEVEL (PR2)

1. Remove the cap from the LSG port.

2. Install the pressure gauge.
3. Position the PLATFORM LEVEL switch to UP or DOWN. Note the maximum reading on the pressure gauge. If the reading is not ± 965 kPa/ .6 bar (140 psi) of the relief pressure shown on the table titled *Relief Valve Pressure Settings*, adjust the pressure setting as necessary.
4. Shut down the engine.
5. Remove the pressure gauge.
6. Install the cap from the LSG port.

STEER FRONT AND REAR (PR2)

1. Remove the cap from the LSG port.
2. Install the pressure gauge.
3. Position the THUMB STEER switch on top of the DRIVE controller to LEFT or RIGHT until the end of the steer cylinder travel. Note the maximum reading on the pressure gauge. If the reading is not ± 965 kPa/9.6 bar (140 psi) of the relief pressure shown on the table titled *Relief Valve Pressure Settings*, adjust the pressure setting as necessary.
4. Shut down the engine.
5. Remove the pressure gauge.
6. Install the cap from the LSG port.

BOOM TELESCOPE - OUT (PR3)

1. Remove the cap from the LSG port.
2. Install the pressure gauge.
3. Position the TELESCOPE controller to OUT until the end of the boom telescope cylinder travel. Note the maximum reading on the pressure gauge. If the reading is not $\pm 1,034.25$ kPa/ 10.3 bar (150 psi) of the relief pressure shown on the table titled *Relief Valve Pressure Settings*, adjust the pressure setting as necessary.
4. Shut down the engine.
5. Remove the pressure gauge.
6. Install the cap from the LSG port.

BOOM TELESCOPE - IN (PR4)

1. Remove the cap from the LSG port.
2. Install the pressure gauge.
3. Position the TELESCOPE controller to IN until the end of the boom telescope cylinder travel. Note the maximum reading on the pressure gauge. If the reading is not ± 430.93 kPa/4.30 bar (62.5 psi) of the relief pressure shown on the table titled *Relief Valve Pressure Settings*, adjust the pressure setting as necessary.
4. Shut down the engine.
5. Remove the pressure gauge.
6. Install the cap from the LSG port.

BOOM LIFT - DOWN (PR5)

1. Remove the cap from the LSG port.
2. Install the pressure gauge.
3. Install the turntable lock pin to prevent the turntable from moving.
4. Position the LIFT controller to DOWN until the end of the lift cylinder travel.
5. Note the maximum reading on the pressure gauge. If the reading is not ± 517.12 kPa/5.17 bar (75 psi) of the reading listed on the table titled *Relief Valve Pressure Settings*, adjust the pressure setting as necessary.
6. Shut down the engine.
7. Remove the pressure gauge.
8. Install the cap from the LSG port.

BOOM LIFT - UP (PR6)

1. Remove the cap from the LSG port.
2. Install the pressure gauge.
3. Install the turntable lock pin to prevent the turntable from moving.
4. Position the LIFT controller to UP until the end of the lift cylinder travel.
5. Note the maximum reading on the pressure

gauge. If the reading is not ± 1103.2 kPa/11.03 bar (160 psi) of the reading listed on the table titled *Relief Valve Pressure Settings*, adjust the pressure setting as necessary.

6. Shut down the engine.
7. Remove the pressure gauge.
8. Install the cap from the LSG port.

SWING (PR7)

1. Remove the cap from the LSG port.

2. Install the pressure gauge.
3. Position the SWING controller to LEFT or RIGHT. Note the maximum reading on the pressure gauge. If the reading is not ± 344.75 kPa/3.44 bar (50 psi) of the relief pressure shown on the table titled *Relief Valve Pressure Settings*, adjust the pressure setting as necessary.
4. Shut down the engine.
5. Remove the pressure gauge.
6. Install the cap from the LSG port.

RELIEF VALVE PRESSURE SETTINGS			
Function	Relief Pressure	Relief Valve	Check Port
SAC Port	1,034.2 kPa/10.3 bar (150 psi)	PR1	Engine Throttle Cylinder
Platform Rotate	19,306 kPa/193.06 bar (2,800 psi)	PR2	LSG
Platform Level	19,306 kPa/193.06 bar (2,800 psi)	PR2	LSG
Steer Front and Rear	19,306 kPa/193.06 bar (2,800 psi)	PR2	LSG
Boom Telescope (Out)	20,685 kPa/206.85 bar (3,000 psi)	PR3	LSG
Boom Telescope (In)	8,618.75 kPa/86.18 bar (1,250 psi)	PR4	LSG
Boom (Down)	10,342.5 kPa/103.42 bar (1,500 psi)	PR5	LSG
Boom (Up)	22,064 kPa/220.64 bar (3,200 psi)	PR6	LSG
Swing	6,895 kPa/68.9 bar (1,000 psi)	PR7	Inline on motor
Pump Stand-by Pressure	3,275.12 kPa/32.75 bar (475 psi)	Pump	PG

SECTION 7

MAINTENANCE

SYSTEM MALFUNCTIONS

When analyzing a system malfunction, use a systematic procedure to locate and correct problems:

- Determine problem.
- List possible causes.
- Devise checks.
- Conduct checks in a logical order to determine the cause.
- Consider remaining service life of components against cost of parts and labor necessary to replace them.
- Make necessary repairs.
- Recheck to ensure that nothing has been overlooked.
- Functionally test failed part in its system.

NOTE

«

Your safety and that of others is always the number one consideration when working around machines.

Safety is a matter of thoroughly understanding the job to be done and the application of good common sense. It is not just a matter of do's and don'ts. Stay clear of all moving parts.

CLEANLINESS

Keep dirt out of working parts to preserve the long life of the machine. Enclosed compartments, seals, and filters keep the supply of air, fuel, and lubricants clean. Maintain these enclosures properly.

Whenever hydraulic, fuel, and lubricating oil lines or air lines are disconnected, clean the adjacent area as well as the point of disconnect. As soon as the disconnection is made, cap, plug, or tape each line or

opening to prevent entry of foreign material. The same recommendations for cleaning and covering apply when access covers or inspection plates are removed.

Clean and inspect all parts. Make sure:

- All passages and holes are open
- Parts are covered to keep them clean
- Parts are clean when they are installed
- New parts are left in their containers until ready for assembly
- Rust preventive compound has been removed from all machine surfaces of new parts before they are installed

REMOVAL AND INSTALLATION

When performing maintenance, do not attempt to manually lift heavy parts when hoisting equipment should be used. Never locate or leave heavy parts in an unstable position. When raising a portion of a work platform - or a complete work platform - securely block the work platform and support the weight of the machine on blocks (rather than by lifting equipment).

When using hoisting equipment:

- Follow hoist manufacturer's recommendations
- Use lifting devices that will allow you to achieve the proper balance of the assemblies being lifted and ensure safe handling

Unless otherwise specified, all removals requiring hoisting equipment should be accomplished using an adjustable lifting attachment. All supporting members (chains and cables) should be parallel to each other and as near perpendicular as possible to the top of the object being lifted.

CAUTION

THE CAPACITY OF AN EYEBOLT DIMINISHES AS THE ANGLE BETWEEN THE SUPPORTING MEMBERS AND THE OBJECT BECOMES LESS THAN 90°. EYEBOLT AND BRACKETS SHOULD NEVER BE BENT AND SHOULD ONLY HAVE STRESS IN TENSION.

Some removals require the use of lifting fixtures to obtain proper balance. The weights of some components are given in their respective sections of the repair manual.

If a part resists removal, make sure;

- All nuts and bolts have been removed
- Adjacent parts are not interfering

DISASSEMBLY AND ASSEMBLY

When assembling or disassembling a component or system, complete each step in turn:

- Do not partially assemble one part and then start assembling another part
- Make all adjustments as recommended
- Always check job after it is completed to see that nothing has been overloaded
- Recheck various adjustments by operating the machine before returning it to the job

PRESSING PARTS

When pressing one part into another, use an antiseize compound or a molybdenum disulfide-base compound to lubricate the mating surfaces.

Assemble tapered parts dry. Before assembling parts with tapered splines, make sure splines are clean, dry, and free of burrs. Position the parts together by hand to mesh the splines before applying pressure.

Parts that are fitted together with tapered splines are always very tight. If they are not tight, inspect the tapered splines and discard the part if the splines are worn.

LOCKS

Lockwashers, flat metal locks, or cotter pins are used to lock nuts and bolts.

Flat metal locks must be installed properly to be effective. Bend one end of the lock around the edge of the part. Bend the other end against one flat surface of the nut or bolt head.

Always use new locking devices on components that have moving parts.

When installing lockwashers on aluminum housings, use a flatwasher between the lockwasher and the housing.

WIRES AND CABLES

Always disconnect batteries prior to working on the electrical system.

If the work platform is equipped with a battery disconnect switch, turn the switch to off prior to working on the electrical system.

When removing or disconnecting a group of wires or cables, tag each one to ensure proper identification during assembly.

SHIMS

When shims are removed, tie them together and identify their location. Keep shims clean and flat until they are reinstalled.

BEARINGS

ANTIFRICTION BEARING

When an antifriction bearing is removed, cover it to keep out dirt and abrasives. Wash bearings in nonflammable cleaning solution and allow them to drain dry. The bearing may be dried with compressed air - **DO NOT SPIN THE BEARING.**

Discard the bearings if the races and balls or rollers are pitted, scored, or burned. If the bearing is serviceable, coat it with oil and wrap it in clean waxed paper. Do not unwrap new bearings until time of installation.

The life of an antifriction bearing will be shortened if not properly lubricated. Dirt in an antifriction bearing can cause the bearing to lock - resulting in the shaft turning in the inner race or the outer race turning within the cage.

DOUBLE ROW, TAPERED ROLLER

Double row, tapered roller bearings are precision fit during manufacture and components are not interchangeable. The cups, cones, and spacers are usually etched with the same serial number and letter designator. If no letter designators are found, wire the components together to assure correct installation. Reusable bearing components should be installed in their original positions.

HEATING BEARINGS

Bearings which require expansion for installation should be heated in oil not to exceed 121°C (250°F). When more than one part is heated to aid in assembly, allow parts to cool. Then press them together again. Parts often separate as they cool and contract.

INSTALLATION

Lubricate new or used bearings before installation. Bearings that are to be preloaded must have a film of oil over the entire assembly to obtain accurate pre-loading. When installing a bearing, spacer, or washer against a shoulder on a shaft, be sure the chamfered side is toward the shoulder.

When pressing bearings into a retainer or bore, uniformly apply pressure to the outer race. If the bearing is pressed on the shaft, uniformly apply pressure on the inner race.

PRELOAD

Preload is an initial load placed on the bearing at the time of assembly. Whether a tapered roller bearing should have preload could depend on any of several conditions; rigidity of the housings and shaft, bearing spread, speed of operation, etc.

To determine whether a bearing requires preload or end clearance, consult the disassembly and assembly instructions pertaining to that bearing.

Care should be exercised in applying preload. Misapplication of preload to bearings requiring end clearance can result in bearing failure.

SLEEVE BEARINGS

Do not install sleeve bearings with a hammer. Use a press and be sure to apply the pressure directly in line with the bore. If it is necessary to drive on a bearing, use a bearing driver or a bar with a smooth flat end. If a sleeve bearing has an oil hole, align it with the oil hole in the mating part.

GASKETS

Be sure the holes in the gaskets correspond with the lubricant passages in the mating parts. If it is necessary to make gaskets, select material of the proper type and thickness. Be sure to cut holes in the right places. Blank gaskets can cause serious damage.

When removed, always install new cylinder head and manifold gaskets using recommended gasket compound on head gaskets to allow uniform sealing.

BATTERIES

Clean batteries by scrubbing them with a solution of baking soda and water. Rinse with clear water. After cleaning, dry thoroughly and coat terminals and connections with an anti-corrosion compound or grease.

If the machine is to be stored or not used for an extended period of time, the batteries should be removed. Store the batteries in a warm, dry place, preferably on wooden shelves. Never store on concrete. A small charge should be introduced periodically to keep the specific gravity rating at recommended level.

CARE AND INSTALLATION OF TEFLON-COATED BUSHINGS

The following instructions must be followed when working with teflon-coated bushings and turned, ground, and polished shafts.

BUSHINGS

- No jiffy wheels or reaming of any kind can be used on coated bushings.
- Once the coating on the bushing is damaged it cannot be used and must be replaced.
- Coat bushing, shaft, and interior of housings with grease before assembling.

SHAFTS

The turned, ground, and polished shafting used in any weldment must be protected from snot blast, paint, or any other damage to shaft surface.

- Any rough or damaged surface on shaft will cause the teflon coating on the bushing to be damaged; therefore, bushing must be replaced.

- All rust or masking residue must be cleaned from turned, ground, and polished shafting prior to installation. Use emery cloth as appropriate.

BUSHINGS AND SHAFT

- When installing bushings on the shaft, proper care must be taken to ensure bushing and shaft are properly aligned so that bushing coating is not damaged.
- I.D. of bushing **MUST** be coated with clean grease before shafts are installed at any assembly level.

HYDRAULIC SYSTEMS

DANGER

EXERCISE EXTREME CARE AROUND PRESSURIZED HYDRAULIC SYSTEMS. DO NOT WORK ON A HYDRAULIC SYSTEM WHILE IT IS IN OPERATION OR UNTIL ALL PRESSURE IS RELEASED.

CLEANLINESS

Contaminants in a hydraulic system affect operation and will result in serious damage to the system components. Dirty hydraulic systems are a major cause of component failures.

KEEP THE SYSTEM CLEAN

When removing components of a hydraulic system, cover all openings on both the component and the work platform.

If evidence of foreign particles is found in the hydraulic system, flush the system. Refer to the hydraulic system in the repair manual.

Disassemble and assemble hydraulic components on a clean surface.

Clean all metal parts in a non-flammable cleaning fluid. Then lubricate all components to aid in assembly.

SEALING ELEMENTS

Inspect all sealing elements (O-ring, gaskets, etc.) when disassembling and assembling hydraulic system components. Installation of new elements is always recommended.

HYDRAULIC LINES

When installing metal tubes, tighten all bolts finger-tight. Then, in order, tighten the bolts at the rigid end, the adjustable end, and the mounting brackets. After tubes are mounted, install the hoses. Connect both ends of the hose with ail bolts finger-tight. Position the hose so it does not rub the machine or another hose and has a minimum of bending and twisting. Tighten bolts in both couplings.

Due to manufacturing methods there is a natural curvature to a hydraulic hose. The hose should be installed so any bend is with this curvature.

REMOVING AIR FROM THE HYDRAULIC SYSTEM

Air entering the hydraulic oil will normally be removed automatically by passage of the hydraulic oil over the baffle in the hydraulic reservoir. However, if a component has been replaced or the reservoir level is too low, air can enter the system. If air becomes entrapped in the hydraulic oil, it may be detectable in pump/motor-operated components by causing noisy operation. Should this occur, check the level of the hydraulic reservoir and replenish as necessary.

Minute leaks may be difficult to locate. Should you encounter a leak that is not readily detectable, use the following method when checking for leaks:

- Seal all normal openings in the hydraulic system and the hydraulic reservoir.
- Using a positive means to control the pressure (i.e., a regulator), pressurize the hydraulic system to 13.8 kPa/0.14 bar - 27.5 kPa/0.28 bar (2 to 4 psi)
- Inspect all joints and fittings for evidence of leaks. A soap solution - applied to fittings and joints - may also prove helpful in detecting minute leaks when the system is pressurized.
- Remove the pressure, repair any leaks found, and reopen any openings (vents, etc.) closed for inspection.
- Refill the hydraulic reservoir after completing any repairs or service.

- Operate all hydraulic circuits several times in both directions. This action should return any entrapped air to the hydraulic reservoir where it can be removed from the hydraulic oil by the hydraulic reservoir vent,

DANGER

USE EXTREME CARE WHEN REMOVING ANY PLUGS OR RESTRICTIONS FROM A HYDRAULIC SYSTEM SUSPECTED TO HAVE ENTRAPPED AIR THAT MAY BE PRESSURIZED. FAILURE TO COMPLY COULD RESULT IN DEATH OR INJURY TO PERSONNEL.

Entrapped air may be removed from cylinders (having wet rods) by cycling. On certain cylinders, a plugged port is provided on the rod end to bleed off entrapped air.

DANGER

DO NOT ATTEMPT TO LOOSEN FITTINGS IN PRESSURIZED LINES OR WHILE THE HYDRAULIC PUMP IS IN OPERATION. FAILURE TO COMPLY COULD RESULT IN DEATH OR INJURY TO PERSONNEL,

If air entrapment should persist, it may become necessary to bleed air by loosening various clamp- and screw-type fittings, if the above procedures fail to eliminate air entrapment, contact your Grove Worldwide distributor.

FATIGUE OF WELDED STRUCTURES

Experience has shown that highly stressed welded structures—when repeatedly subjected to varying stresses caused by twisting, shock, bending, and intentional and/or unintentional overloads—often become subject to weld cracking which may be attributed to fatigue of the welded joint. This condition is not uncommon in construction equipment.

Equipment should be periodically inspected for evidence of weld fatigue. The frequency of these inspections should be commensurate with the:

- Age of equipment
- Severity of application

- Experience of operators and maintenance personnel

The following high-stress areas are applicable to Grove Worldwide machines. A visual inspection of these areas should be made part of the owner's planned preventive maintenance program:

- Main frame - generally in the area of doubler plates and crossmembers
- Counterweight support structures
- Frame, axle, and suspension mounting structures
- Hydraulic cylinder end connections
- Power telescope boom - wear pad retaining structures, hydraulic cylinder attaching points, boom pivot shaft retaining structures (boom models only)
- Turntable bearing connection - where bearing is welded to the work platform superstructure or chassis (boom models only)

The items listed above are provided as a guide. Do not limit your inspection plan to the areas listed. A thorough visual inspection of all weldments is good practice.

If you require more detailed inspection instructions and/or repair procedures, contact your local Grove Worldwide distributor for assistance.

WELDING FROM/ON WORK PLATFORMS

When welding from/on work platforms, follow these precautions:

- When welding from the platform, always run the welder ground wire directly to the structure that is being welded. Do not allow any part of the work platform to contact welding rods, holders, ground terminals, or the structure being welded. Do not ground the welder through the machine as this can cause arcing inside the turntable bearing (boom models).
- When welding on the frame on all work platforms, connect the welder ground wire to the machine frame - as close to the area being welded as possible. When welding on the superstructure on all boom machines, connect the welder ground wire to the machine superstructure - as close to the area being

welded as possible. This is to prevent arcing inside the turntable bearing.

Use of proper torque values is extremely important. Improper torquing can seriously affect performance and reliability.

LOCTITE®

DANGER

LOCTITE® - TYPE ADHESIVES CONTAIN CHEMICALS THAT MAY BE HARMFUL IF MISUSED. READ AND FOLLOW THE INSTRUCTIONS ON THE CONTAINER.

Always follow the directions on the Loctite® container. Not all Loctite® types are suitable for all applications. Different types of Loctite® are specified throughout the repair manual.

The following types of Loctite® - brand adhesives are available from Grove Worldwide Lifetime Customer Support.

<u>LOCTITE® ADHESIVES</u>	
<u>Loctite® Number</u>	<u>Grove Worldwide Number</u>
277	9999100806
242	9999100805
592	9999100804
587	9999100926

FASTENERS AND TORQUE VALUES

Use bolts of the correct length. A bolt that is too long may bottom before the head is tight against the part it is to hold. If a bolt is too short, there may not be enough threads engaged to hold the part securely. Threads can be damaged. Inspect them and replace fasteners as necessary.

Torque values should correspond to the type of bolts, studs, and nuts being used unless otherwise noted.

Torque tables are provided by Grove Worldwide for reference when performing maintenance.

NOTE

Some special applications require variation from standard torque values. Reference should always be made to component overhaul procedures for recommendations.

Special attention should be given to the existence of lubricant, plating, or other factors that might require variation from standard torque values.

When maximum recommended torque values have been exceeded, the fastener should be replaced. If installation is in a tapped hole, check the thread with a gage and then replace the bolt.

If reusing previously installed grade 5 bolts that have not been over torqued, the bolts shall be visually inspected for cracks and thread damage, and replaced if discontinuities are found. Bolts are not to be rethreaded or reworked.

All lower grade fasteners must also be properly tightened to assure a good assembly. This tightening can be achieved by using a procedure (such as the turn-of-the-nut) or by applying the measured torque.

When unfinished self-locking nuts (such as the plastic patch or dimpled types) are coated with a light oil, the run down torque that would normally be added to the wrench setting need not be added. Run down torque is the force necessary to turn the nut on a free thread.

When referring to applicable torque charts, use values as close as possible to the torque values shown to allow for wrench calibration tolerance. An erratic or jerking motion of the wrench can easily result in excessive torque. ALWAYS use a slow wrench movement and STOP when the predetermined value has been reached.

Torque wrenches are precision instruments and are to be handled with care to ensure calibrated accuracy. Calibration checks should be made on a scheduled basis. Whenever the wrench might be either overstressed or damaged, it should immediately be removed from service until recalibrated.

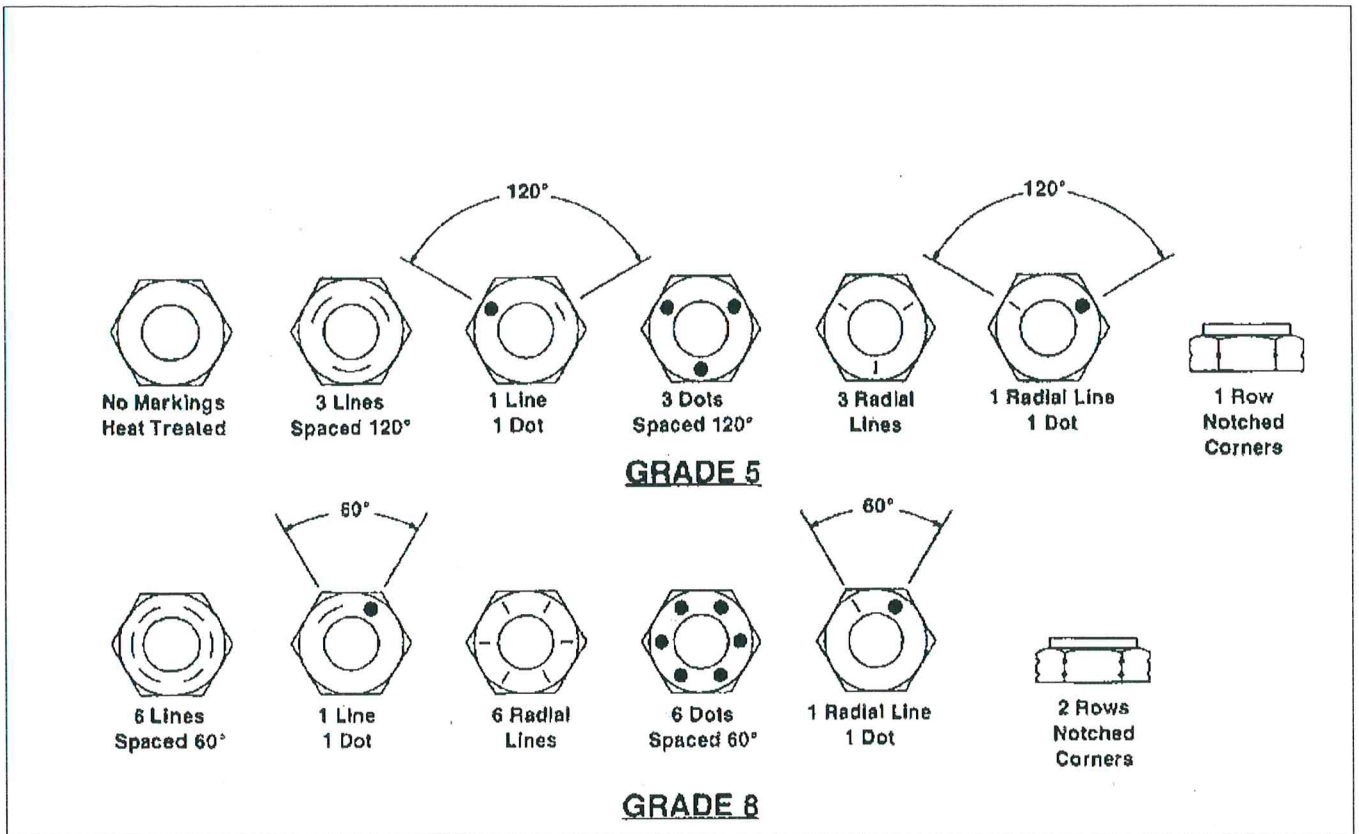

Nut Identification

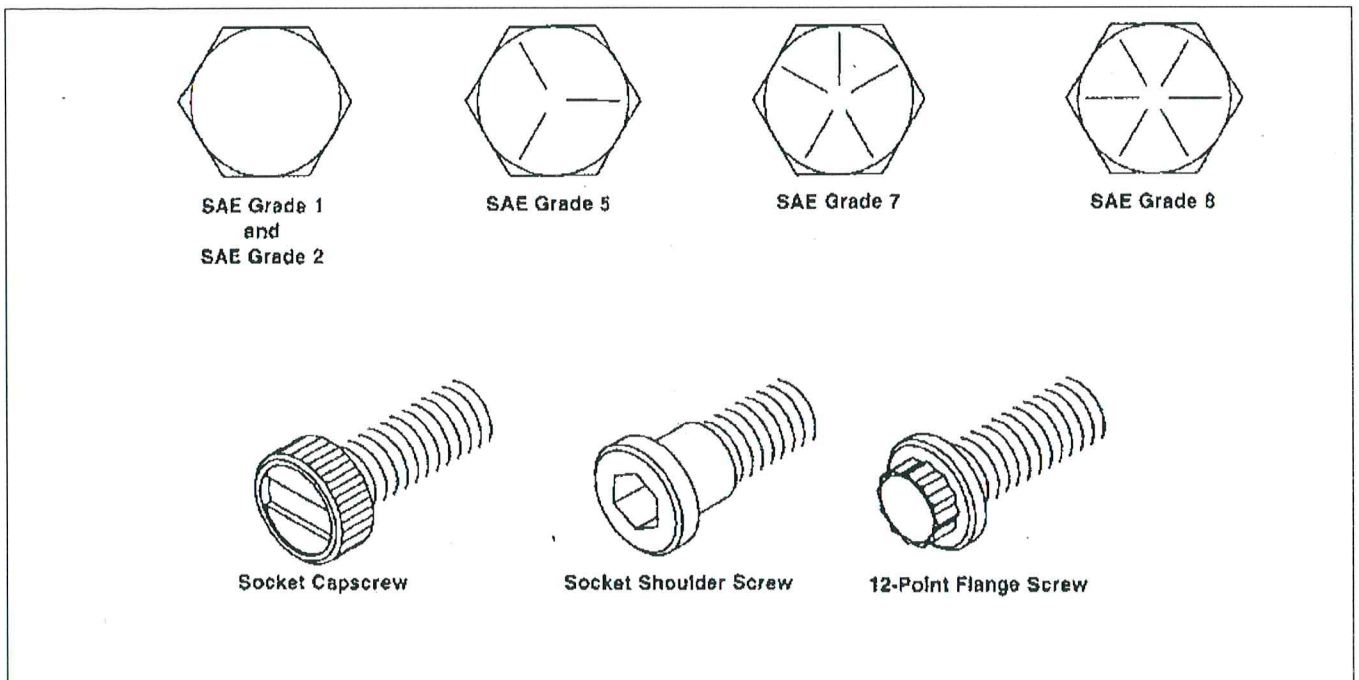

Bolt Head Identification

**Torque Values for Unfinished Fasteners with No Special Lubrication
Fine Threads**

FINE THREAD CAPSCREW	TORQUE VALUE RANGE (FOUNDS-FEET)													
	1/4	5/16	3/8	7/16	1/2	9/16	5/8	3/4	7/8	1	1-1/8	1-1/4	1-3/8	1-1/2
SAE Grade 1/Grade 2	6.3	12	22	34	52	76	108	172	230	340	535	751	1032	1221
	5.8	10	20	32	48	70	100	158	212	314	493	693	952	1127
SAE Grade 5	10	21	36	57	88	126	182	312	458	658	882	1251	1704	2288
	9	19	34	53	81	116	167	287	421	606	814	1155	1572	2105
SAE Grade 8	14.5	26	53	85	125	177	250	425	672	1009	1500	2092	2833	3640
	13.5	24	49	79	115	163	230	393	620	931	1380	1925	2605	3360
Socket Capscrew	14.5	26	53	85	125	177	250	425	672	1009	1500	2092	2833	3604
	13.5	24	49	79	115	163	230	393	620	931	1380	1925	2605	3640

NOTES:

1. Studs should be torqued using capscrew figures when grade is known.
2. Surface hardness is measured using the Rockwell "B" and "C" scales.
3. Torque values for zinc-plated fasteners are the same as for unfinished fasteners.
4. When either part of a nut/bolt combination is cadmium plated, multiply above values by 0.90. When nut and bolt are both cadmium plated, multiply above values by 0.80.

**Torque Values in Newton-Meters (Nm) for Metric Fasteners with No Special Lubrication
Coarse Threads**

GRADE	BOLT DIAMETER (MM)														
	M4	M5	M6	M7	M8	M10	M12	M14	M16	M18	M20	M22	M24	M27	M30
8.8	3.1	6.5	11	19	27	53	93	148	230	319	447	608	774	1134	1538
	2.8	5.9	10	17	25	49	85	136	212	294	413	562	714	1046	1420
10.9	4.5	9.2	16	26	38	75	130	212	322	455	629	856	1089	1591	2163
	4.1	8.5	14	24	35	69	120	195	298	418	581	790	1005	1469	1997
12.9	5.4	11	19	31	45	89	156	248	387	532	756	1029	1306	1910	2595
	4.9	10	17	28	42	83	144	228	357	490	698	949	1206	1763	2395

NOTES:

1. Torque for fine threads is 8% higher.

**Torque Values in Foot-Pounds for Metric Fasteners with No Special Lubrication
Coarse Threads**

GRADE	BOLT DIAMETER (MM)														
	M4 .157	M5 .197	M6 .236	M7 .276	M8 .315	M10 .394	M12 .472	M14 .551	M16 .630	M18 .709	M20 .787	M22 .866	M24 .945	M27 1.06	M30 1.18
8.8	2.3	4.8	8.1	14	20	39	69	109	170	235	329	448	548	836	1134
	2.1	4.3	7.4	12.5	18	36	63	100	156	217	304	414	526	771	1047
10.9	3.3	6.8	11.8	19	28	55	96	156	237	335	464	631	803	1173	1594
	3	6.3	10.3	17.6	26	51	88	144	220	308	428	582	741	1083	1472
12.9	4	8.1	14	23	33	66	115	183	285	392	557	758	963	1408	1913
	3.6	7.4	12.5	20.6	31	61	106	168	263	361	514	699	889	1299	1765

NOTES:

1. Torque for fine threads is 8% higher.

**Torque Values for Unfinished Fasteners with No Special Lubrication
Coarse Threads**

COARSE THREAD CAPSCREW	TORQUE VALUE RANGE (POUNDS-FEET)													
	1/4	5/16	3/8	7/16	1/2	9/16	5/8	3/4	7/8	1	1-1/8	1-1/4	1-3/8	1-1/2
SAE Grade 1/Grade 2	5.5	11	20	31	47	69	97	156	210	312	493	685	919	1100
	5	9	18	29	43	63	89	144	194	288	455	633	849	1015
SAE Grade 5	9	19	32	52	78	114	156	270	416	606	813	1141	1519	2028
	7.7	17	30	48	72	106	144	249	384	560	751	1053	1403	1865
SAE Grade 8	12.5	26	48	73	120	161	234	385	615	929	1342	2043	2496	3276
	11.5	24	44	67	110	143	216	355	567	857	1234	1885	2296	3024
Socket Capscrew	12.5	26	48	73	120	161	234	385	615	929	1342	2043	2496	3276
	11.5	24	44	67	110	143	216	355	567	857	1234	1885	2296	3024
Socket Shoulder Capscrew	5	12	23	-	42	-	100	174	-	346	-	-	-	-
	3	9	21	-	38	-	92	160	-	320	-	-	-	-

NOTES:

1. Studs should be torqued using capscrew figures when grade is known.
2. Surface hardness is measured using the Rockwell "B" and "C" scales.
3. Torque values for zinc-plated fasteners are the same as for unfinished fasteners.
4. When either part of a nut/bolt combination is cadmium plated, multiply above values by 0.90. When nut and bolt are both cadmium plated, multiply above values by 0.80.

KNOW YOUR TORQUE WRENCH! Flexible beam type-wrenches - even though they might have a preset feature - must be pulled at right angles and the force must be applied at the exact center of the handle. Force value readings must be made while the tool is in motion.

Rigid handle-type torque wrenches are available with torque limiting devices that can be preset to required values and which eliminate dial readings.

LUBRICATION

When special high-pressure lubricants (such as Never-Seez and molybdenum disulphite) are used on non-plated fasteners, multiply the torque values in the table titled "Torque Values for Unfinished Fasteners with No Special Lubrication - Coarse Threads" by a factor of 0.90. To have an effect on the resulting torque, the lubricant must be applied under the bolt head or nut being rotated as well as on the threads.

When either part of a standard nut/bolt combination is cadmium plated, use the table titled "Torque Values for Unfinished Fasteners with No Special Lubrication - Coarse Threads" and multiply the torque values by a factor of 0.90. Multiply by 0.80 when nuts and bolts are both plated.

NOTE

To convert pounds-foot of torque to kilograms meter (kgm), multiply the pounds-foot quantity by 0.138255.

NOTE

To convert pounds-inch of torque to kilograms centimeter (kgcm), multiply the pounds-inch quantity by 1.152.

NOTE

When multipliers and/or special tools are used to reach hard-to-get-at spots, ensure torque readings are precisely calculated. Identification of fastener grade is always necessary.

When marked as a high-strength bolt (grade 3, 5, etc.), the mechanic must be aware that he is working with a highly stressed component and the

fastener should be torqued accordingly.

PROCEDURE FOR PROPER APPLICATION, OF PRIMER AND ADHESIVE/SEALANT

This procedure outlines the proper application and curing method for primer (Loctite Primer T7471) and medium-strength adhesive/sealant (Loctite 242) and should only be used in areas designated by assembly and installation procedures.

PRIMER APPLICATION

1. Make sure threaded surfaces (both male and female) are free of dirt and oil. Apply a light spray coating of primer to both male and female parts to be joined to clean and accelerate the curing process. It is not necessary to bathe the threads in primer.
2. Allow parts to dry prior to adhesive/sealant application.

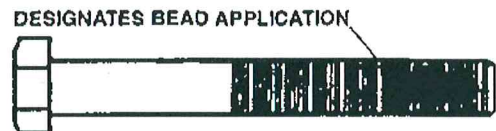

Adhesive/Sealant Application

ADHESIVE/SEALANT APPLICATION.

1. Apply a bead perpendicular to the thread (several threads wide) in the approximate area of threaded engagement.
2. In a blind-hole application, apply a bead - or several drops of adhesive - into the bottom of the hole to be hydraulically forced up during engagement.
3. After application and engagement of mated threads, fixturing will occur within five minutes if primed prior to engagement. Fixturing may take up to 30 minutes on unprimed parts.
4. Full strength is achieved in 24 hours. Maximum ultimate strength is achieved using no primer with this specific threadlocking adhesive.

NOTES

SECTION 8

PREVENTIVE MAINTENANCE AND INSPECTION

GENERAL

The information and in this section show you the items to check when performing daily, weekly, semi-annual/annual, monthly, and quarterly maintenance and required inspections on Grove® Manlift® aerial work platforms.

NOTE

This material does not replace any pre-operational checks required by an owner or a local or state safety board.

NOTE

Federal regulations require that written, dated, and signed inspection records be maintained.

NOTE

Perform lubrication as outlined in this Operator's, Safety, and Maintenance Handbook or in the machine-specific Repair Manuals which are available for purchase from Grove U.S. L.L.C. Lifetime Customer Support.

NOTE

Maintenance Inspection Manuals with daily inspection service logs, weekly inspection service logs, semi-annual/annual inspection service logs, monthly inspection service logs, quarterly inspection service logs, service and repair record charts, and intial/signature verification record charts are available for purchase from Grove U.S. L.L.C. Lifetime Customer Support.

REQUIRED PREVENTIVE MAINTENANCE, AND INSPECTION

DAILY PREVENTIVE MAINTENANCE AND INSPECTION

NOTE

Not all items listed below will apply to every work platform.

Daily preventive maintenance/inspections should include checking the following items:

- Operator's, Safety, and Maintenance Handbook
- Work platform
- Controls/indicators
- Lights
- Tilt alarm
- Motion alarm
- Engine crankcase
- Fuel tank
- LP-fuel tanks
- Brakes
- Tire condition/pressure
- Non-drive wheel ends
- Hydraulic reservoir
- Swing brake
- Boom and attachments
- 8-m (26-foot) cutout switch
- Power track

NOTES

- Fuel tank filter screen
- Drive assembly mounting bolts
- Turntable bolts
- Gearbox mounting bolts
- Swivel mounting bolts
- Battery cables
- Wiring harnesses
- Structural area of work platform
- Rotator end cap
- Lubrication

NOTES

SECTION 9

TRANSPORTATION INSTRUCTIONS

TRANSPORTATION VEHICLE

PREPARATIONS

1. Under the controlled conditions outlined below—and those described in the appropriate Operator’s and Safety Handbook—it is acceptable to have the tilt alarm sounding (indicating that the machine has exceeded 5°).
2. Verify the transport vehicle’s rated weight capacity. Ensure the loading surface, blocking, and tie-down chains and/or straps are sufficient to withstand the work platform’s weight prior to loading the work platform for transport.
3. Review the Operator’s and Safety Handbook specifications to verify the work platform’s weight, length, height, and width prior to loading the work platform.
4. Visually inspect the loading and hauling surfaces. Remove obstructions from the loading ramp and transport vehicle’s hauling surface prior to loading the machine on the transport vehicle.
5. Inspect for moisture, debris, mud, or grease on the loading and hauling surfaces that may effect loading, hauling, or unloading of the work platform from the transport vehicle.
6. Avoid loading or unloading the work platform near overhead power lines or other energized power sources. The work platform is not insulated. Death or serious injury could result from contact with—or inadequate clearance from— electrical power lines or equipment. Maintain a minimum distance of 6 m (20 feet) from any energized power source.
7. Low speed drive function must be used when loading and unloading the work platform onto—and from—a transport vehicle.
8. The machine should have the travel pin lock engaged and the boom fully lowered and in line

with the direction of travel. If the boom must be raised to allow the platform to clear the ground, the boom must be kept as low as possible while allowing clearance.

9. Loading or unloading the work platform onto- or from - a transport vehicle using a ramp requires special care. The work platform must be mechanically assisted in order to ascend or descend slopes exceeding the specific model’s theoretical gradeability. Refer to table titled *Theoretical Gradeability*. Review the Operator’s and Safety Handbook for instructions relative to towing—some models may require torque hub and/or wheel lock disengagement.

DANGER

**DISENGAGEMENT OF TORQUE HUBS
WILL ALLOW UNIT TO FREE WHEEL.**

CAUTION

GRADEABILITY IS A THEORETICAL VALUE WHICH INDICATES THE MAXIMUM SLOPE THAT A MACHINE HAS BEEN DESIGNED TO NEGOTIATE STRAIGHT UP AND DOWN IN LINE WITH THE SLOPE IN THE FORWARD OR REVERSE DIRECTION WITH THE MACHINE IN THE TRAVEL CONFIGURATION. GRADEABILITY IS EXPRESSED AS A PERCENTAGE.

THEORETICAL GRADEABILITY	
MODEL	GRADEABILITY
T60 (MZ66)	30%
T60XT (MZ66XT)	50%

10. Load and unload the work platform on a firm level surface. Do not drive the work platform near holes, drop offs, curbs, slopes, or obstacles.
11. Follow the instructions in the Operator's and Safety Handbook relative to machine tie down and transport.
7. Strap and block rotator support securely to transport vehicle bed. Telescope the boom and lower at least 30° to a position that allows it to be strapped and blocked.
8. Place a plastic bag over platform controls. Then, secure platform controls to platform rails.

PREPARATION OF THE WORK PLATFORM FOR TRANSPORT

NOTE

Refer to Section 1 - Introduction in this handbook for work platform specifications (i.e., dimensions, weight, center of gravity, etc.).

Prepare work platform for transport as follows:

CAUTION

FAILURE TO PROPERLY SECURE THE WORK PLATFORM DURING TRANSPORT COULD RESULT IN COMPONENT DAMAGE.

1. Fully retract and lower boom/articulating jib (if so equipped) over the rear (travel position).
2. Inspect the work platform for loose or unsecured items. Remove such items before proceeding.
3. Follow transportation vehicle instructions and position work platform on transport vehicle. Turn off all work platform power. Push the EMERGENCY STOP switch in the platform controls. Turn off the IGNITION switch in the ground controls and remove the key.
4. Chock wheels (as necessary) to restrain the work platform.
5. Secure aerial work platform using four tie-down points provided on frame. To secure frame to transport vehicle, fasten chains through frame tie-downs to transport vehicle bed.
6. Secure railings, bars, gates, and platform chains to prevent their moving during transport.

PERFORM THE FOLLOWING PROCEDURE AFTER REACHING YOUR DESTINATION

1. Make sure transport vehicle is on a level surface and there is sufficient space—free of obstructions—to off load the work platform.
2. Reinstall platform controls. Install/replace any item removed or repositioned for transport.
3. Remove banding material, cardboard padding, straps, blocking, chocks, chains, and any other material used for tie-down and transport.
4. Carefully off load the work platform from the transport vehicle in the reverse order used in loading the work platform.

PREPARATION FOR OPERATION AFTER TRANSPORT

1. Make sure all components requiring daily lubrication have been serviced. Refer to Section 5 - LUBRICATION in this handbook for locations of components and proper lubrication amounts.
2. Check condition of tires. Remove work platform from service if tires exhibit severe cuts or if foreign objects are embedded in treads.
3. Check the hydraulic reservoir and filter. Refer to Section 5 - LUBRICATION in this handbook.
4. Check the tilt alarm system by pressing down on one corner of the tilt level sensor switch. The tilt buzzer should sound when the tilt alarm system is functioning properly.
5. Ensure emergency lowering valve is closed.
6. Turn power ON by positioning keyed ground controls IGNITION switch to the right ON position (power to platform controls).

7. Pull up EMERGENCY STOP switch in platform controls.
8. Depress the ENABLE switch
9. Operate each switch and controller on both the platform controls and ground controls - to ensure all machine functions are operating satisfactorily - before driving or using machine to perform work.

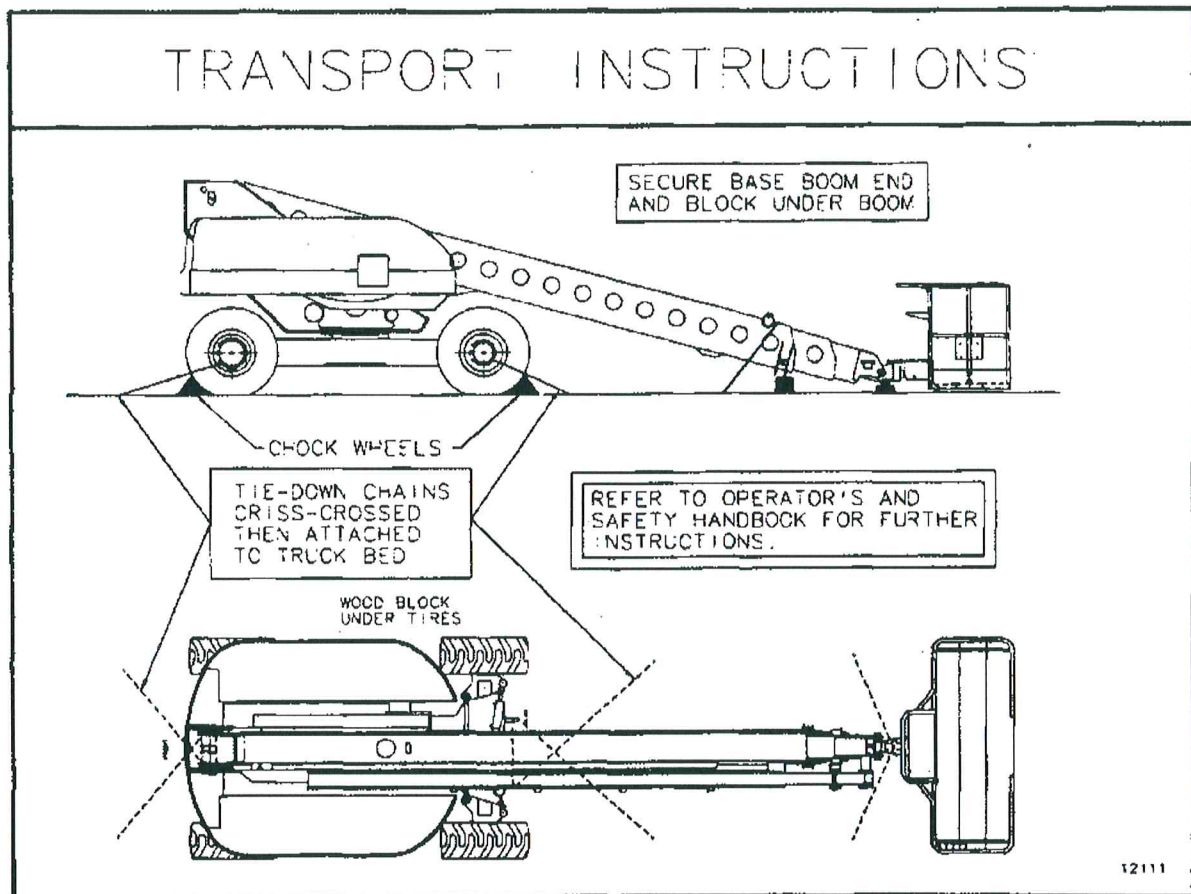

NOTE: Use cardboard padding at all banding, points-as required-to prevent paint damage.

Transport Procedure Diagram

NOTES
